

RYK VECTOR WAVE
SYNTH VOICE
USER MANUAL
U1.24 FIRMWARE

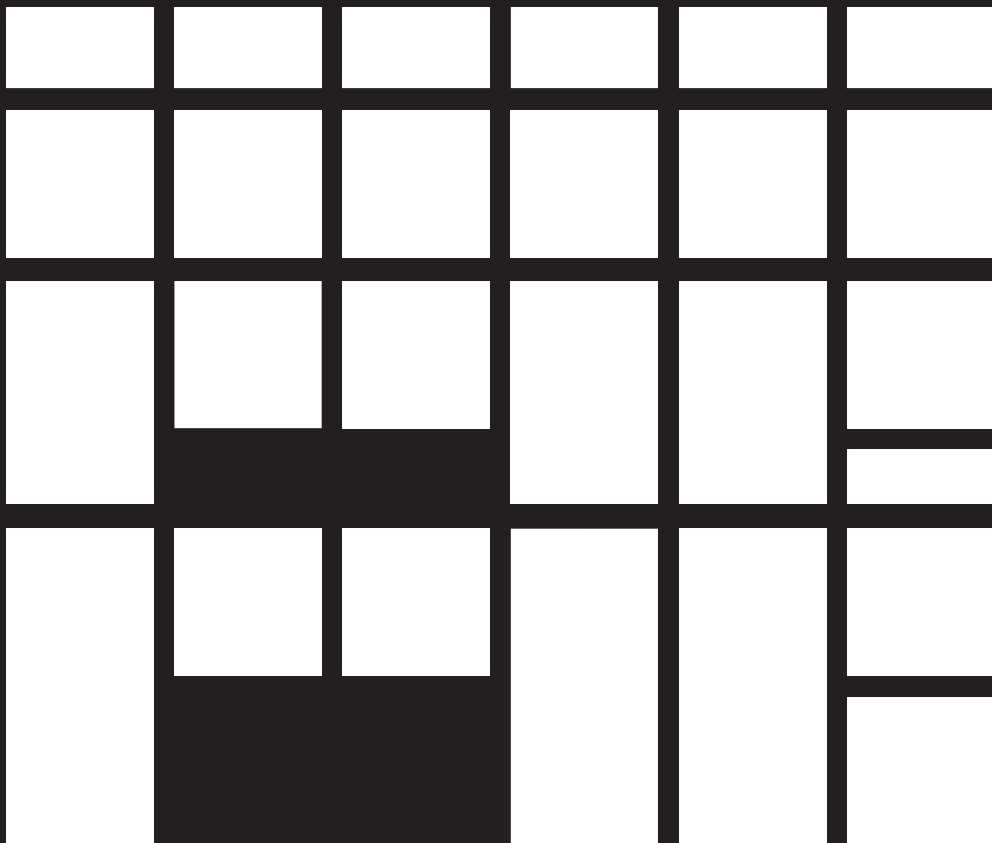

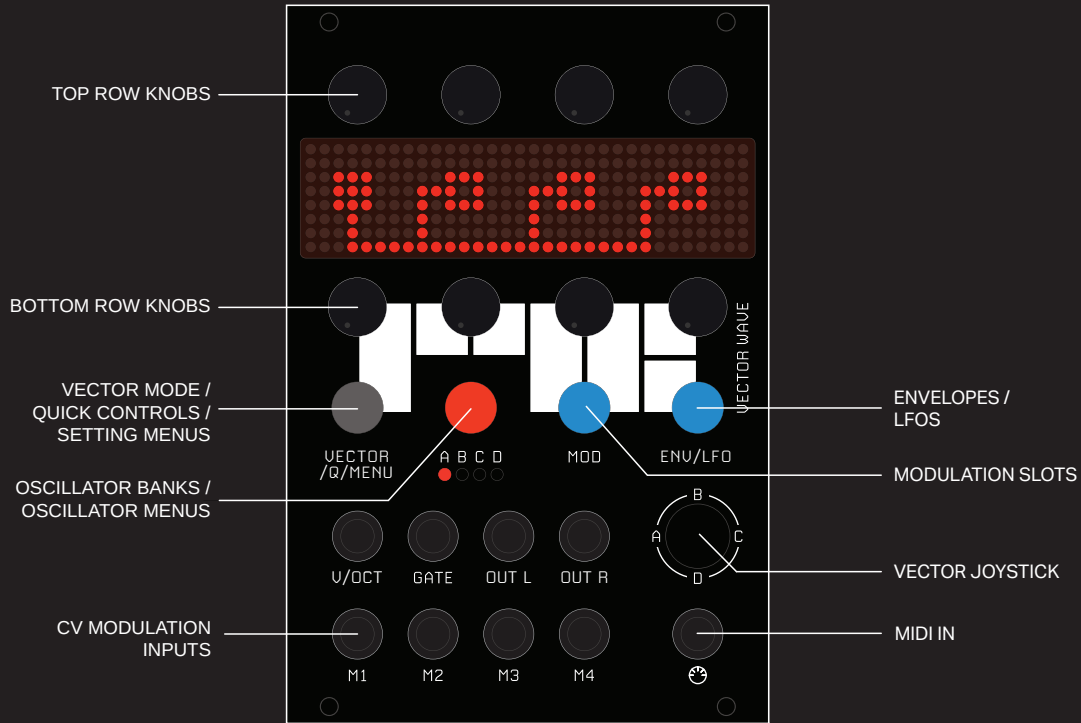

RYK VECTOR WAVE - USER MANUAL V1.24 FIRMWARE

The **Vector Wave** is a FM & Harmonic synthesiser voice, with four bank vector synthesis or true four voice polyphony with in built Envelopes and LFO modulation sources.

OVERVIEW

The **Vector Wave** has 16 sine wave oscillators, divided into four **Banks A,B,C,D**.

These oscillators can be configured in series or parallel combinations to create complex FM or additive waveforms and textures.

If you are not familiar with FM synthesis, please take a look at this overview from Wikipedia
https://en.wikipedia.org/wiki/Frequency_modulation_synthesis

There are four Modes, that allocate the Oscillator Banks in different ways: **VECT**or, **POLY**phonic, and **MULTI**-timbral.
The Mode is set via the **Settings Menu** [see PAGE 12]

VECT1/2 mode creates a monophonic voice from all four Banks, mixed via the joystick or vector animation.

POLY mode duplicates the settings from Oscillator Bank A to all other Banks to create four voices of polyphony.

MULT mode uses each oscillator Bank as a separate voice, trigger-able from consecutive MIDI channels, or using the **Expander module**.

Oscillator banks can be created with quick set-ups of harmonic spreads, random formant style clusters, and chords groups in the

Oscillator Menu (see PAGE 5) which also allows for saving and loading of individual banks.

When using **VECT1/2** mode, the joystick position controls the mix between the four **Banks A,B,C,D**.

The joystick position **Vectors** can be stored, and then animated or triggered from modulation sources for complex repeatable timbre changes.

There are 6 available **Modulation Slots** (see PAGE 8), allowing external CV sources, and the internal modulation sources to be routed to any parameter within the Vector Wave.

User Voice Patches containing all the Oscillator Bank settings, modulation patches, envelope and LFO settings etc can be stored in internal memory and recalled at a later time from the **Setting Menu** (see PAGE 12).

MIDI input can be used instead of V/Oct GATE, and also allows velocity, aftertouch and MIDI CCs as modulation sources.

MIDI Program Change messages automatically load User Voice Patches when received by the Vector Wave.

The optional **Expander module** adds three more V/Oct and Gate inputs, allowing the module to be utilised as four separate individual synth voices.

Dimensions

17 HP
25 mm deep

Power consumption

60 mA +12V
5 mA -12V
0 mA 5V



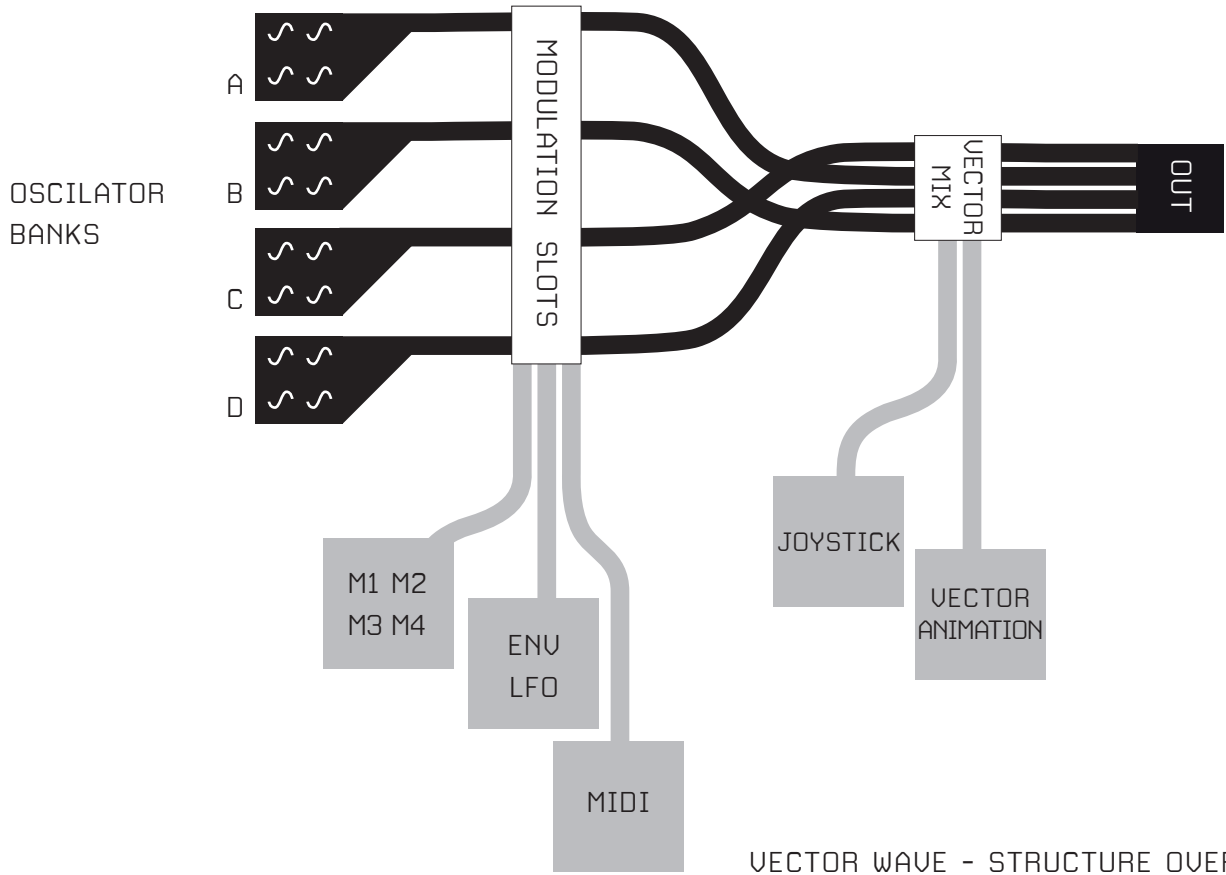

VECTOR WAVE - STRUCTURE OVERVIEW



QUICK START GUIDE FOR THE IMPATIENT !

Push the **Grey Menu Button** once or twice until you see the **Settings Menu**, [LOAD, SAVE, MODE, OUTPUT, MIDI, TUNE etc]

Rotate the bottom left knob to select '**LOAD**'.

With this menu you can load a **DEF**ault settings voice, or a previously stored voice from numbers 1-30. [the Vector Wave ships with a selection of ready stored voices]

Rotate the bottom right knob to select and preview a Voice Preset, push the knob to load the voice.

To gain a quick understanding we recommend loading the Default Voice, where all the settings are reset to basic options.

Push the **Red Oscillator Button** to choose an **Oscillator Bank**.

Use the top row knobs to adjust the harmonic frequency of each oscillator in the Bank, use the bottom row knobs to adjust the level of each oscillator.

You can also push the bottom row knobs to change the oscillator algorithm connections to create FM [XM cross modulation] between A modulation oscillator is shown as a solid box shape, a carrier oscillator is shown as an outline box shape. Signal flow if from left to right.

Use the bottom row level knobs to adjust the level of modulation oscillator, essentially adjusting the amount of modulation.

For non FM synthesis usually the loudest oscillator would be kept to 1 for the base frequency, the other oscillators can be adjusted to other harmonics to create the sound.

If you cannot hear any sound, move the Joystick towards the Bank you are adjusting [i.e. A for Bank A]

Once you have created some sounds in each Bank, use the Joystick to

crossfade between the four Oscillator Banks.

To adjust the Voice Envelopes push the **Blue ENV/LFO** button, use the top row knobs to adjust ENV1 [amplitude] or ENV2 [XM cross modulation level]. Repeated pushes flip between ENV1,ENV2

Push the **Grey Button** to leave the **Settings Menu**, use the top row knobs to adjust the performance settings in the **Quick Controls Performance Page** [XM,WP,FD,DT].

XM – Adjust the amount of FM cross modulation [if being used]

WP – warps the waveforms from sine to tri to pulse

FD – adjusts the amount of wave folding

DT – adjust the detune spread of all the oscillators

Use the **Settings Menu** to adjust TUNE [Semitones] or FINE [Fine tuning] etc.

Once you have mastered these steps, please read through the rest of the manual to gain a deeper understanding of the Vector Wave features such as the powerful **Modulation Slots**.





A B C D

OSCILLATOR BANKS

Pushing the Red button accesses the Oscillator Bank mode. Repeated pushes cycle between each bank, **A,B,C,D**.

Each bank has 4 oscillators. Each oscillator has a column of top and bottom knobs, to control the parameters.

The Oscillator Display has four pages, depending on which controls are being used:

The top row knobs control the harmonic frequency of each oscillator [1-32]. Pushing them will switch between the oscillator harmonic and the oscillator fine tune [+/- 0-99]

The bottom knobs control the amplitude level of each oscillator.

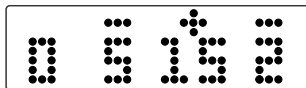
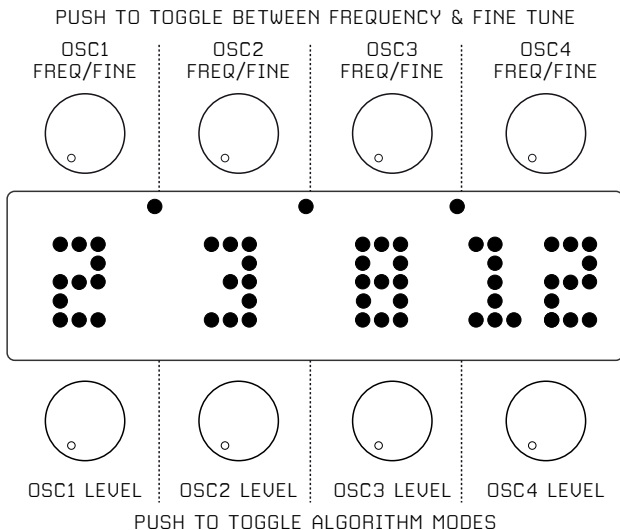

FINE TUNE MODE

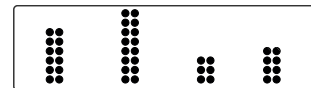

LEVELS MODE

Pushing any of the bottom row knobs will enable the FM algorithm mode.

In the FM algorithm mode, pushing a knob will toggle the associated oscillator between carrier, series modulator, or parallel modulator. The signal flow for modulation oscillator to carrier oscillator is from left to right.

A modulation oscillator is shown as a solid box shape, a carrier oscillator is shown as an outline box shape.

The modulation oscillator, modulates the carrier to create rich and harmonically complex sounds.

The amount of modulation is controlled by the level of the modulation oscillator, the level of Envelope 2, and also the XM [cross modulation] amount in the **Q Quick Performance page** [see PAGE 11].

It is generally best to use small amounts of modulation oscillator level for subtle and usual sounds, increasing the amount results in generally more extreme sounds.

The relationship of the oscillator harmonic frequencies plays a big part in how FM cross-modulation will sound. Try changing the oscillator harmonics within an FM setup to hear how the sound changes.



Example 1

Oscillator 1&2 are combined in parallel to modulate oscillator 3. Oscillator 4 is not modulated.



Example 2

Oscillator 1 is modulating oscillators 2,3,& 4.

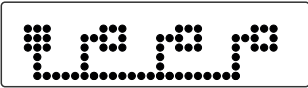

Example 3

Oscillator 1 is modulating oscillator 2, oscillator 3 is modulating oscillator 4

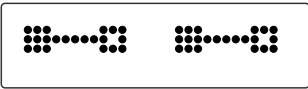

A B C D

OSCILLATOR MENU

Pushing and holding the Red Oscillator button for a few seconds will activate the Oscillator Menu, pushing the button again for a few seconds will exit the Oscillator Menu.

The Oscillator Menu enables quick setups of the Oscillator Bank frequencies, chords, random clusters, and also loading and saving of banks.

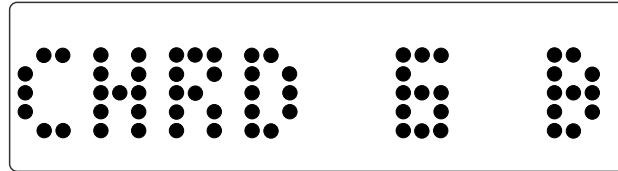

MENU FUNCTION

[CHORD #] DESTINATION
CHORD MODE ONLY BANK[S]

Use the bottom left knob to select the function, and the bottom right knob to select the destination bank[s] that will be affected.

In **CHRD** mode, the 3rd bottom row knob selects the chord.

In **LOADB & SAVEB** the operation affects the current bank indicated by the **ABCD** Bank LEDs.



INIT - Resets all banks.

CPY TO - Copy the currently selected bank, indicated by the **ABCD** Bank LEDs, to the destination bank[s]

ALL - Automatically assign ascending harmonics to the destination bank[s].

ODD - Automatically assign ascending odd harmonics to the destination bank[s].

RND - Automatically assign random harmonics to the destination bank[s]

CLUST - Automatically assign random formant clusters of harmonics to the destination bank[s]

CHRD - Allocates 1 of 14 types of chord to the destination bank[s]

LOADB - Load an Oscillator Bank from the store number, to the Bank indicated by the **ABCD** Bank LEDs

SAVEB - Save the Bank indicated by the **ABCD** Bank LEDs to the store number

The root frequency of the CHRD mode is defined by the first oscillator in the destination bank.

HARMONIC VIEW

Pushing and holding any of the top row knobs for a few seconds will activate the Harmonic View, pushing again for a few seconds will exit the view.

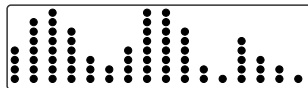

This display view shows the harmonics of all four banks of oscillators across the display.

The harmonic frequencies can be adjusted with the top row knobs, whilst the amplitude level can be adjusted with the bottom row knobs. The active Oscillator Bank harmonics will appear brighter than the other banks.

NB. If there are **BF** (band filter) or **LF** (low filter) used in the **Modulation Slots**, their effect will be visible on the harmonic display.



ENV/LFO

ENVELOPES & LFOs

Pushing the ENV/LFO button accesses the Envelope and LFO modes.

Repeated pushes will cycle between ENV1 & ENV2, or LFO1 and LFO2 depending which page you are using.

Use the top row knobs to select the Envelope page, and the bottom row knobs to select the LFO page.



ENVELOPE PAGE

There are two ADSR type envelopes, ENV1 controls the amplitude of the Vector Wave voice outputs, ENV2 controls the XM [cross modulation FM] amount of each Oscillator Bank.

The top row knobs control the Attack, Decay, Sustain, Release settings of the current envelope.

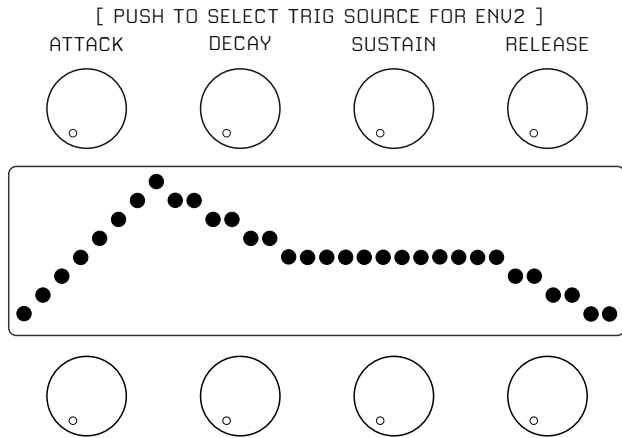

The Envelope settings can be global [**GLB**] or per Bank [**BNK**] [Refer to Page 12 **Settings Menu - ENV** to select].

If using bank [**BNK**] envelopes you can select a different Bank Envelope by holding the Blue ENV button then pressing the Red Bank button.

The default trigger source of ENV2 is the Gate input, but this can be changed to an alternate input when using singular [**GLB**] envelopes. To do this push any top row knob to cycle through the trigger source options: Gate, M1, M2, M3, M4, or OFF.

LFO PAGE

There are two LFOs. They can be used to add movement to a sound by modulating a destination attribute of an Oscillator Bank, such as amplitude [AM]. [Refer to Page 8 **Modulation Slots**]

Use the bottom row knobs to select one of the following waveforms Sine, Triangle, Saw, Ramp, Square, Random, Noise, and to adjust the frequency of the LFO.

The LFOs can be free run, or reset from one of the following trigger sources, Gate, M1, M2, M3, M4. Use the 2nd bottom row knob to choose this option.

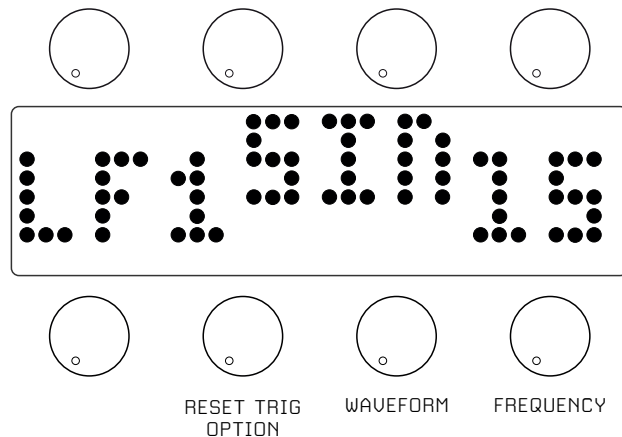



MOD

MODULATION SLOTS

Pushing the Mod button accesses the **Modulation Slots**. Repeated pushes will cycle between all the slots.

Each slot allows a modulation source to modulate a destination attribute, such as an LFO modulating Wave Fold [FD].

Modulation sources include control voltages from one of the M1-M4 inputs, or internal sources such as the LFOs, Joystick, and Envelopes.

Each destination, for example Oscillator Bank A, has a sub option [suffix] for example WP [Wave Warp], which is the destination attribute to be modulated.

MOD
ANTENUVERTER



MOD
OFFSET

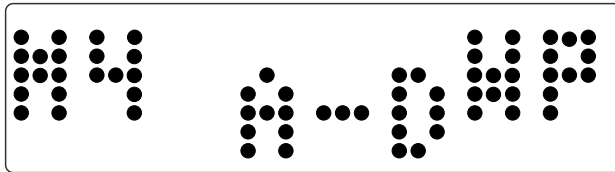

MOD SOURCE



DESTINATION



DEST.
ATTRIBUTE



Use the bottom row knobs to select the modulation source, destination, and destination suffix.
Use the top row knobs to select the modulation amount [Attenuverter], and modulation offset. These can be positive or negative values.

For example to create an inverted [subtractive] modulation, dial the offset amount to a positive value, and dial the modulation amount to a numerically similar negative value. [see example below].

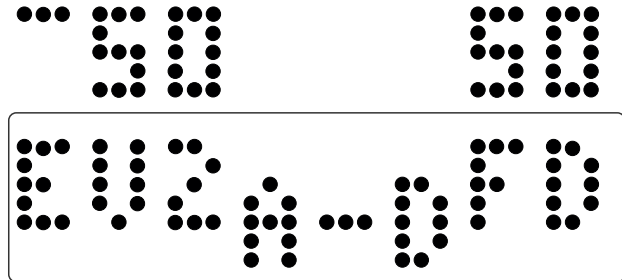

In this example Envelope2 is modulating the FD amount [Wave Fold] of Oscillator Banks A through to D.
The Envelope is used subtractively to reduce the amount of Wave Folding as the Envelope signal grows, and conversely increase the amount of Wave Folding as the Envelope signal reduces.



Modulation Sources:

M1,M2,M3,M4 – External CV sources from M1,M2,M3 or M4

JYX, JYY - Joystick X or Y position

EV1/EV2 - Envelope1 or Envelope2

LF1,LF2 - LFO1 or LFO2

CV - The V/OCT pitch input

MVL - MIDI Velocity

MAT - MIDI Aftertouch

MMD - MIDI Modulation Wheel

MBD - MIDI Pitch Bend

CC2-CC49 - MIDI CCs

Gate** - GATE Trigger

M1[T] - The M1 Trigger input **

** These are only available as trigger sources when **VEC** is selected as a destination

Modulation Destinations:

A-D, or **A,B,C,D** - Oscillator Banks

AM – Amplitude modulation

FM – Frequency modulation

XM – Oscillator Cross modulation [Amount of FM algorithm modulation]

WP - Waveform warp [Continuously variable wave shape from Sine to Saw to Pulse]

HM – Harmonic shift of modulators oscillators

DT – Detune spread amount

PN – Output Pan of bank for output jacks [-99 = 100% OUT L , +99 = 100% OUT R]

FD – Wave folding [classic wave folding for complex harmonic generation]

BF – Harmonic Band pass filter frequency [passes a narrow band of the oscillator harmonic frequencies]

LF – Harmonic Low pass filter frequency [passes a low shelf of the oscillator harmonic frequencies]

VEC – Vector animation position from a modulator. Or Trigger playback from Gate or M1[T] input,

LF1,LF2 - LFO1 or LFO2

AM – Amplitude modulation of LFO

FM – Frequency modulation of LFO

WV – Waveform select of LFO

EV1/EV2 - Envelope1 or Envelope2

A,D,S,R,AD,AR – Modulation of Attack, Decay, Sustain, Release of Envelope

JOY - Joystick Bank Mix [Disables physical Joystick mix]

X,Y,XY

RST - YS / NO – Push selection knob to reset ALL the Modulation Slots



VECTOR
/Q/MENU

VECTOR/Q & MENU

Pushing the grey button will cycle between the Vector/Q modes, OR the Settings Menu. When in the Vector/Q mode, using the top row knobs to show the **Q Quick performance controls** page, use the bottom row knobs to show the **Vector Page**.

VECTOR PAGE [not available in polyphonic or multitimbral modes]

When the module is set to a **VECTOR** mode the Joystick is used to continuously control the mix between the **A,B,C,D** banks.

The Vector pages allow for Recording of the Joystick movement or Joystick positions, which can later be replayed or triggered for automated timbre changes.



There are two types of **VECTOR** animation, **VEC1** allows the Joystick movement to be recorded over time, **VEC2** allows you to store four Joystick vector positions, which are used to recreate a vector movement.

VEC1

The speed of the vector for recorded and triggered playback can be set using the bottom right knob [3-99]. The recorded position of the Joystick is represented in the centre box, an inverse R on the left indicates recording mode.

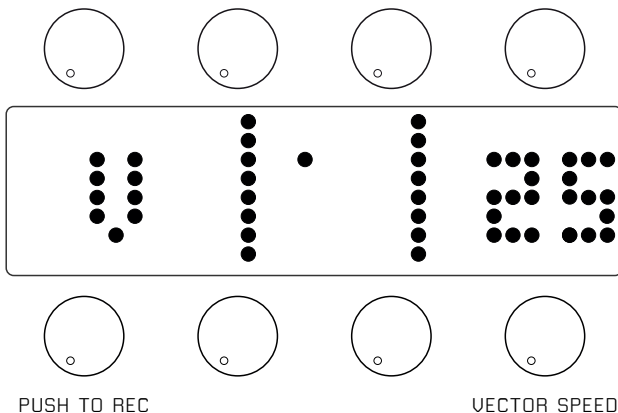

To Record a Joystick vector movement, select the desired vector speed [20 is a good starting speed], push the bottom left knob to start recording whilst moving the Joystick.

To playback the vector movement from a trigger source, use the

destination **'VEC'** in a modulation slot, and select GATE or M1T as a trigger source. The speed is set by the bottom right knob on the Vector page.

Instead of triggering the replay, the vector movement can instead be continuously animated through time from a modulation source such as an LFO or external CV.

To do this set the destination **'VEC'** in a modulation slot, and select a modulation source [except Gate/M1T].

The speed value on the Vector Page DOES NOT affect the animation time. If you need to audition the Joystick again, you can turn off the vector animation by setting the **'VEC'** modulation source to **'--'** in the Modulation Slots.

VEC2

The four cell boxes represent the position of four vector XY joystick positions

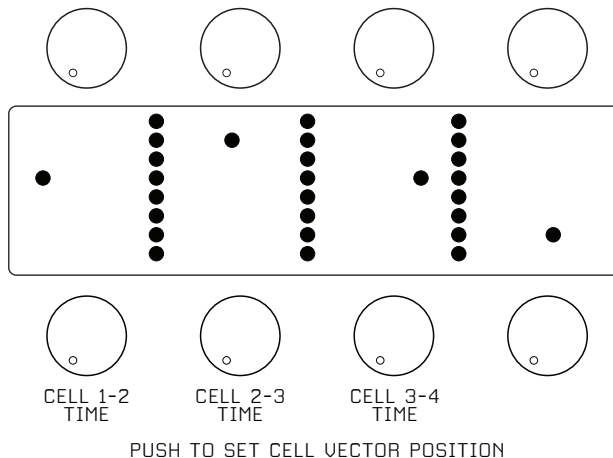

Move the Joystick to a desired mix position, and push one of the bottom row knobs to store the Vector position. Repeat for all four **Cell** boxes.

Use the 1st three bottom row knobs to adjust the time-speed between each **Cell**.

EG: knob 1, adjusts the time between Cell1 and Cell2, knob 2 adjusts the time between Cell2 and Cell3, etc.

The playback of the vector animation is represented by a vertical bar, that scrolls across the display.

To playback the vector movement from a trigger source, use the destination '**VEC**' in a modulation slot, and select **GATE** or **M1T** as a trigger source.

The speed between each cell is set by the three bottom row knobs on the Vector page.

Instead of triggering the replay, the vector movement can instead be continuously animated through time from a modulation source such as an LFO or external CV.

To do this set the destination '**VEC**' in a modulation slot, and select a modulation source [except Gate/M1T].

'Q' QUICK CONTROLS PERFORMANCE PAGE

This menu allows easy access to some of the creative Oscillator Bank parameters, giving quick access and hands on control to the timbre of the sound.

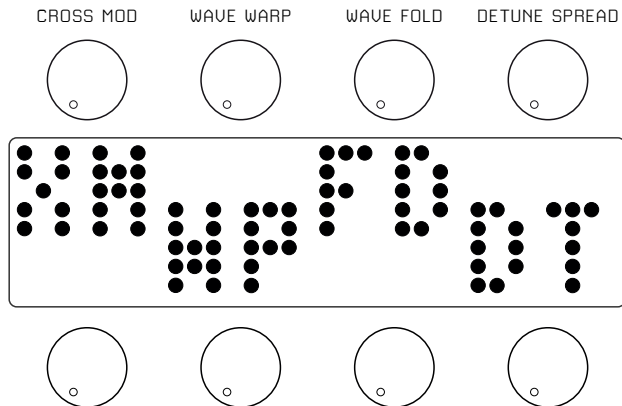

XM - Oscillator Cross modulation amount [0= no cross modulation, 99 = maximum]

WP - Warp amount of the oscillator waveforms [0 = Sine, 40 = Saw, 99 = Pulse]

FD - Fold amount of the oscillator waveforms [0= no folding, 99 = maximum]

DT - Control of oscillator detune amount [Spreads out the tuning of the Oscillators to create movement and depth]

NB the Q Performance Controls affect **ALL** Oscillator Banks.
 For affecting a single Bank, select the bank as a destination in a **Modulation Slot**, select the destination attribute such as FD and use the offset control to adjust the amount.

SETTINGS MENU

This menu allows for Loading and Saving of Voices, selection of Oscillator Bank Modes modes and other settings such as Tuning and MIDI.

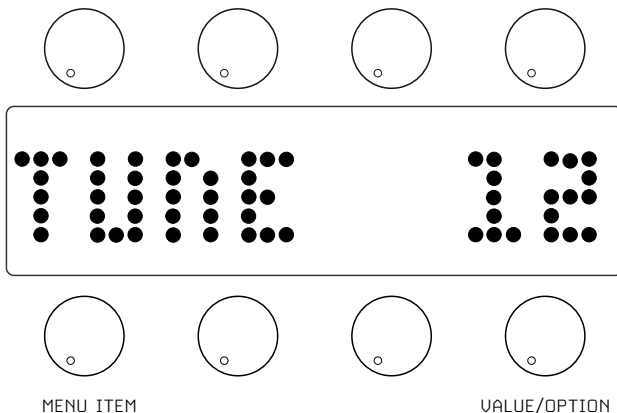

Use the bottom left knob to select from the following menu settings:

LOAD – Load voice from memory. Turn the bottom RHS knob to select the voice number, you will hear a preview of the voice. To Load the voice, push the knob.

SAVE – Save voice to memory, turn the bottom RHS knob to select a voice number, push the knob to save.

MODE – Allocation modes of Oscillator Banks.

VEC1 = Monophonic Voice from all Banks mixed by Joystick or vector animation Type1

VEC2 = Monophonic Voice from all Banks mixed by Joystick or vector animation Type2

POLY = Polyphonic mode, uses BANK A settings as the source for four voices

MULT = Multitimbral Polyphonic mode allocates each Bank as a separate voice [for Expander, or MIDI]

If using MIDI in MULT mode each voice is allocated to consecutive MIDI channels

Eg if the MIDI channel is set to 3, then in MULT mode Bank A is CH3, Bank B is CH4 etc.

NB In POLY or MULT mode Vector Synthesis is not available.

OUTPUT – Use the top row knobs to Pan the output of each Bank **A,B,C,D** to the L or R outputs, or anywhere in between. Pushing a knob will reset the Pan to centre [both L & R outputs]

NB if using only one output jack set the Output Pans to this jack only.

MIDI – Selects MIDI OFF, or MIDI channel [1-12] for MIDI input.

Push for MIDI Note ON/OFF. [indicated by note symbol]

NB With MIDI active, **MIDI Program Change** messages Load User Voice patches automatically, use with caution !!!

TUNE - Sets the master tuning in semitone steps [12 = C3]

FINE - Sets the master fine tuning [+/- 0-99]

ENV - Envelope mode. Select Global [**GLB**] or per Bank [**BNK**] ENV settings

SCOP - Sets the delay time [in seconds] before the oscilloscope screen save appears, also can be turned off.

XPTUNE - Fine tune control for Expander V/Oct inputs. Push the top RHS knob to store the tuning values.

CONNECTION JACKS

V/OCT – This is the pitch CV input [0v-6v] that all oscillator harmonics are multiples of

GATE – This is the Gate input that triggers ENV1, & ENV2. It can also be used to trigger the Vector Animation

OUT L - OUT R – These are the audio outputs of the module. Use Output in the **Settings Menu** to Pan individual Banks to either output or anywhere between the two.

M1-M4 – These are CV modulation inputs [+/-5v, +8v on newer modules] which can be used via the Modulation Slots as modulation sources for all aspects of sound, such as Cross Modulation amount [XM] or Wave Warp [WP] etc

M1[T] – Can also be used as a trigger source for Vector animation playback.

M1-M4 – Can also be used as trigger sources for ENV2, or LFO1/LFO2 resets.

MIDI IN – This is a TRS MIDI input which can be used instead of the V/OCT & Gate inputs to control the Vector Wave pitch and Gate. To use MIDI and MIDI CCs, select a MIDI channel in the Settings Menu. On the back of the module there is a micro switch to set the polarity of the TRS MIDI to TYPE B [default for RYK products] or TYPE A.

On the back of the module is a 10 pin header for connection to a Eurorack Power source using the included ribbon cable, please make sure you align the red or white edge of the cable with the "stripe" indicator on the PCB by the 10 pin header.

There is also a 12 pin header to connect the Vector Wave Expander module. **DO NOT ATTEMPT TO CONNECT ANYTHING ELSE TO THIS** If you have a Vector Wave Expander module, use the included 12 way cable to connect it to the Vector Wave

Please make very sure you align the Red edge of the cable with the "stripe" indicator on both the Vector Wave and teh Expander. Failure to do so, or connecting to the wrong pin header WILL result in damage to the Vector Wave and Expander module.

FIRMWARE UPDATES

The firmware for the Vector Wave can be updated, please check our website for any new releases.

rykmodular.bigcartel.com/firmware-updates

Here's how to install the firmware:

Power up the module first.

On the back of the module are two micro switches, labelled "**FIRMWARE**" and "**RESET**".

Push and hold the Firmware button, then press the Reset button momentarily whilst still holding the Firmware button.

Release the Firmware button.

Plug a USB B micro cable from the module to a computer. Make sure it is a high quality cable that supplies data, some micro USB cables only supply power.

Connect the cable directly to your computer, not via a USB hub.

You should see a USB Disc show up on your computer named "RPI-RP2".

Copy or drag the UF2 firmware file into the "RPI-RP2" disk.

If successful, the disk will 'eject' automatically, and the module will restart with the new firmware.



VECTOR WAVE EXPANDER INSTRUCTIONS

If you have an Expander module, lucky you !
Please follow these steps for setting up and using with the Vector Wave.

Carefully connect the Expander to the Vector Wave following the instructions on page 13.

Do not screw the Expander module into you rack yet, you will need the back accessible, be careful not to let any of the metal circuit board pins touch any rack metal work. If necessary rest the module on some paper or plastic.

Look at the back of the Expander, and you will see a micro switch at the top end of the module, one side is labelled **0V**, the other side is labelled **5V**. Set the switch to **0V**.

First we need to calibrate the Vector Wave to your Expander module.

Switch on your rack power to the Vector Wave, whilst holding down the **Grey** button and the ENV/LFO **Blue** button.
Keep holding these buttons until you see the firmware revision number, followed by '**EXP CAL**' on the display.

Press the bottom right knob to start the calibration.
This is done in two stages, first the module will calibrate to **0V**, which you have already set on the back of the expander.
Next the display will indicate **5V**, when you see this, quickly set the micro switch to **5V**.

When the calibration is finished '**DONE**' will show on the display.
Make sure you then set the micro switch to 0V, and power off the Vector Wave.
Now you are ready to use the Expander.

The expander is used with the multitibral **MULT** mode on the Vector Wave.
Go to the **Settings Menu**, select **MODE**, and chose **MULT** from the options.

Now each Bank of the Vector Wave acts as a separate synth voice, each one controlled by a separate pair of V/OCT & Gate inputs.

Bank **A** is assigned to the V/OCT & GATE jacks on the Vector Wave panel.
Banks **B,C,D** are assigned to the V/OCT & GATE jacks on the Expander.

You can set-up individual sounds for each Bank, and use them as separate voices to create a multitimbral setup. Perhaps using different sequencers or keyboards for each voice.

Each Bank has it's own Envelope settings for **ENV1** and **ENV2**, the current Envelope is indicated by the ABCD Bank LEDs.
To select a different Bank whilst in Envelope mode, simply push and hold the Blue ENV button then press the Red Bank button.

If you would like to use the expander as a polyphonic controller, say from a CV keyboard, then duplicate the Bank you would like to use, to all the other Banks.
This can be achieved using the '**CPY TO**' and '**ALL**' option in the Oscillator Menu.

Remember you can use the **Output** option in the **Settings Menu** [see page 12] to assign which Banks go to the **L or R output** jacks on the Vector Wave.

Have fun !



Name your Voices !

- 1.....
- 2.....
- 3.....
- 4.....
- 5.....
- 6.....
- 7.....
- 8.....
- 9.....
- 10.....
- 11.....
- 12.....
- 13.....
- 14.....

- 15.....
- 16.....
- 17.....
- 18.....
- 19.....
- 20.....
- 21.....
- 22.....
- 23.....
- 24.....
- 25.....
- 26.....
- 27.....
- 28.....
- 29.....
- 30.....



Name your Oscillator Banks !

1.....

2.....

3.....

4.....

5.....

6.....

7.....

8.....

9.....

10.....



Do some nice drawings here !



1

