

# 2hp Swarm

## Hyper Oscillator

### Tech Specs

Width: 2HP  
Depth: 45mm  
Power Consumption:  
+12V=85mA, -12V=7mA,  
+5V=0mA

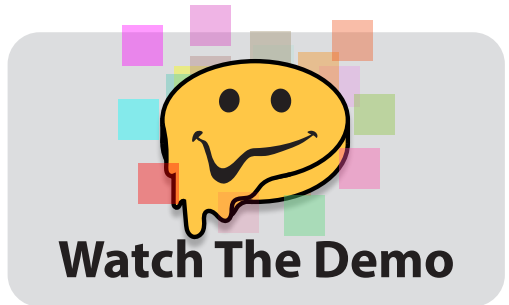

### Voices CV Input

Range: -5V to +5V

### Voices

Controls the number of active oscillators. Only 1 oscillator is active when the knob is fully counter clockwise.

20 oscillators are active when the knob is at the center position. From there, the number of active oscillators increments to dozens of oscillators (max of 88 for Saw, 55 for Pulse) when the knob is fully clockwise.

### Freq 1V/Oct Input

Range: -5V to +5V

### Freq

Controls the macro pitch of all active voices. Tracks 1v/oct.

### Audio Output

Range: 10Vpp

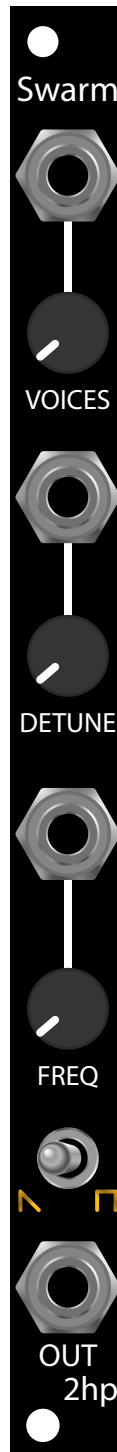

### Detune CV Input

Range: -5V to +5V

### Detune

Controls the amount detune applied to each oscillator. The first half of the knob provides tasteful detune, while the second half provides chaotic detune.

No detune is applied when the knob is fully counter clockwise.

### Wave Toggle

Toggles between sawtooth (left) and pulse (right) waveforms.

# Module Installation

- To install your 2hp module, locate a space with the appropriate HP in your rack for installation.
- Next, connect the module's power cable to your power supply. The cables on this end are keyed, though you should make sure to align the red stripes on both connectors to ensure safe and proper connection. Our illustration uses a flying bus cable, though the same action applies for busboards/alternate power solutions. See the figure below for reference:

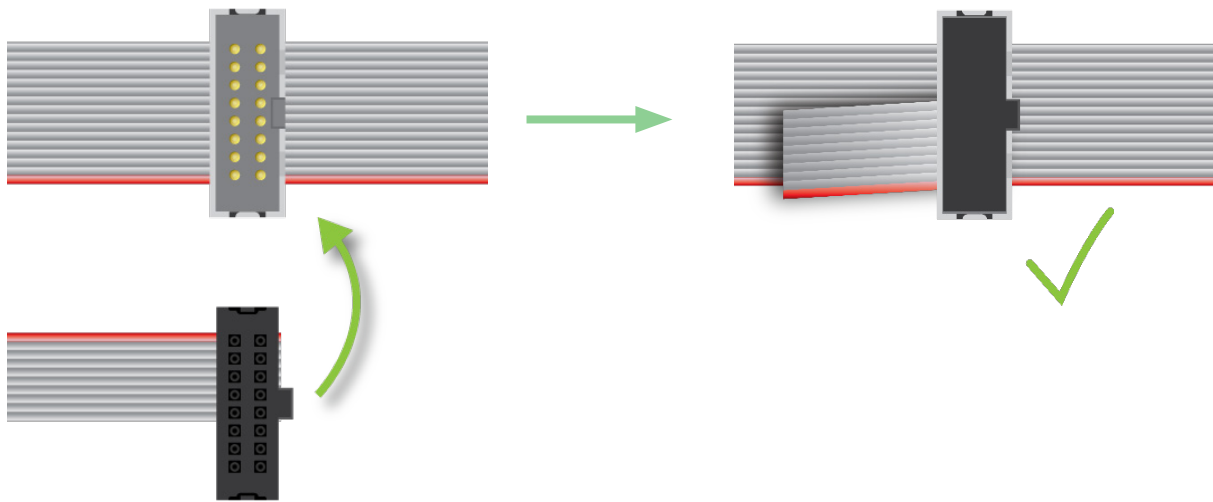

- Next, make sure your module's power cable is properly connected to your module. For 2hp modules, confirm that your cable's red stripe aligns with the white marker line on the module's PCB, just above the power header. You may notice that even though there is only 1 row of 5 pins on your 2hp module, but 2 rows on the power cable. You can use either row of 5 pin connectors on the cable with your module, so long as the red stripe is properly aligned. See figure below for reference:

- Finally, mount your module to the rails using 2.5mm mounting screws and the included sliding mounting nuts. Your module is now ready to be powered on and patched!

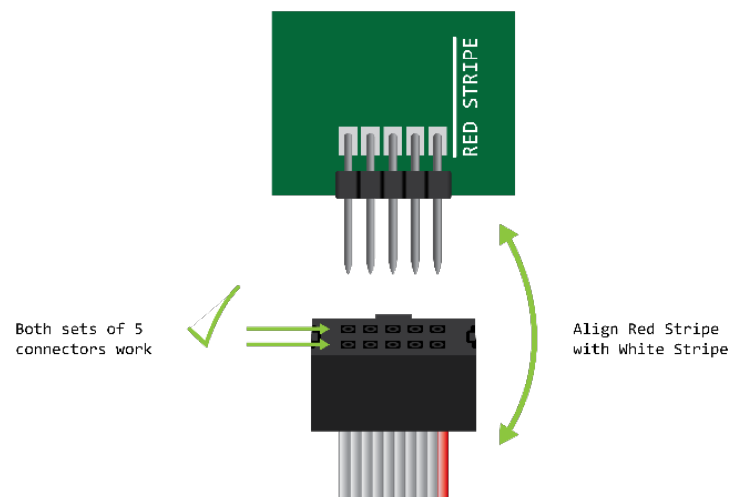

# Module Pairings

---

Swarm is a versatile sound source on its own, but here are a few considerations from our line up that we think work great with Swarm!



## Lo-Fi

Lo-Fi makes a perfect pairing with Swarm!

Crunch up your swarming saws with the digital mode on Lo-Fi, or patch together a wobbly, vintage synth melody with the analog mode.

## EG

Though its envelope is simpler than what's offered on our ADSR module, EG's curve and amplitude controls are perfect for dialing in the shape of your super-saw stabs.

Combine with a VCA, and you are ready to sequence your trance or hardcore voice!



## MMF

Having an analog, state-variable filter in Swarm's signal patch is helpful for adding shaping, dynamics, and timbral transitions to your super-oscillator.

High-pass out your trance lead, or patch together a squelching bass line. The pairings don't get much better than this.

## VCA

Pair our analog dual VCA with EG above and Swarm to have your super-saw voice ready to go!

Use one VCA channel to shape your sound, while using another channel to attenuate any modulation you may be using on Swarm.

