

## 1. Introduction

Module **A-163** is a **voltage controlled audio frequency divider**.

The frequency of the input signal (preferably the rectangle output of a VCO) is divided by an **integer factor N** ( $N = 1, 2, 3, 4 \dots$  up to about 20). The **output waveform** is **rectangle** with 50% duty cycle.

The **divisor N** can be adjusted **manually** and modulated with an external **control voltage** (e.g. from LFO, ADSR, Random, MIDI-to-CV, Theremin, Light-to-CV, analog sequencer) with attenuator.

The following table shows the differences between the divider modules available in the A-100 system.

	A-115	A-113	A-163
Divisor setting	fixed	manually	voltage contr. + manually
Divisor range	2, 4, 8, 16	1... 24 integer	1... 20 integer
No. of outputs	4 (mixed)	4 (mixed+single)	1
Output waveform	rectangle	sawtooth	rectangle

## 2. Overview

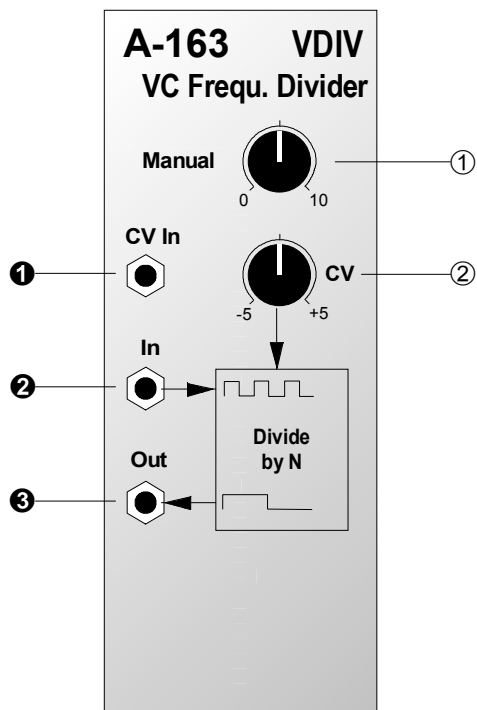

### Controls:

- ① **Manual:** Control for manual setting of the integer dividing factor N
- ② **CV :** Symmetric (negative-0-positive) attenuator for control voltage at input ①
  - *fully clockwise:* max. positive level
  - *middle position:* level 0
  - *fully counterclockwise:* max. negative level

*For the first production series the inscription of the CV knob ② is wrongly 0...10 instead of -5...0...+5. The informations in this manual are correct, i.e. left stop = -5, middle position = 0, right stop = +5.*

### In- / Outputs:

- ① **CV In :** Control voltage input
- ② **In :** Audio input (preferably the rectangle output of a VCO or LFO), i.e. the master frequency for the divider
- ③ **Out :** Audio output of the frequency divider (rectangle)

### 3. Controls

#### ① Manual

With knob ① the **divisor N** is **manually** adjusted. **Integer division** of an audio frequency leads to the so-called **subharmonics**. The table in fig. 1 shows the subharmonic frequencies and pitches of an audio signal C5 (= 523,2 Hz) as master frequency input for the A-163.

Divisor	Freq. [Hz]	Pitch
1	523,2	C <sup>5</sup>
2	261,6	C <sup>4</sup>
3	174,6	F <sup>3</sup>
4	130,8	C <sup>3</sup>
5	103,8	A <sub>s</sub> <sup>2</sup>
6	87,3	F <sup>2</sup>
7	73,4	D <sup>2</sup>
8	65,4	C <sup>2</sup>



**Fig. 1:** *Subharmonics* of an audio signal with pitch C5

It becomes apparent that the subharmonics are equivalent to the tones of the **minor chord scale**.

☞ The term "subharmonic" is not quite correct as the A-163 output waveform is rectangle with a marked harmonic spectrum in contrast to the "pure" sine waves used in the harmonics theory. For details concerning harmonic contents of different waveforms please refer to the A-110 or A-111 manual (VCO's). For details about subharmonics please refer to the A-113 manual.

#### ② CV

The positive/negative **attenuation** and **inversion** of the control voltage fed into socket ① is adjusted with control ②. The following connections are valid :

Position	Amplification	Effect
-5	-1	invertiert CV
0	0	full attenuation
5	1	original CV (not inverted)

☞ The manual setting of control ① and the external control voltage fed into socket ① and attenuated/inverted with control ② are internally added to generate the resulting control voltage that defines the divisor N.

## 4. In- / Outputs

### ❶ CV In

The external control voltage (e.g. from an LFO or ADSR) used to modulate the divisor N is fed into the **CV input ❶**.

### ❷ In

Socket ❷ is the **audio input** of the module. This input is connected to the audio source (waveform preferable rectangle from an VCO or LFO). The frequency of this signal (= master frequency) is divided by N.

### ❸ Out

Socket ❸ is the output of the module. Here the **subharmonic** (rectangle) is available.

#### Frequency division of control signals

The output ❸ of the module is AC-coupled. This means that no slow signals (e.g. 0.5 Hz LFO) can be divided. To obtain a DC-coupled output the capacitor C7 on the A-163 pc board has to be replaced by a jumper (short circuit). This modification leads to a 0/+5V rectangle output that can be used for slowly changing signals too. Please refer to the service manual for the position of C7.

## 5. User Examples

### Sub-Oscillator

With the A-163 an audio sub-oscillator can be realized very simply. The rectangle output of a VCO is connected to the audio input of the A-163. The audio outputs of the VCO (e.g. sawtooth) and the A-163 are mixed together e.g. with an A-138b. Thus one obtains a VCO with sub-oscillator to enhance the bass sound of the VCO. The interval between VCO and sub-oscillator can be set manually or voltage controlled.

### Subharmonic Glissando

One obtains very interesting effects if a dynamically changing control voltage (e.g. from ADSR, LFO, Joy Stick, Theremin, Random or similar) is used to define the divisor N of the A-163. This leads to a special kind of glissandos containing only the subharmonics of the master frequency.



## 6. Patch-Sheet

The following diagrams of the module can help you recall your own **Patches**. They're designed so that a complete 19" rack of modules will fit onto an A4 sheet of paper.

Photocopy this page, and cut out the pictures of this and your other modules. You can then stick them onto another piece of paper, and create a diagram of your own system.

Make multiple copies of your composite diagram, and use them for remembering good patches and set-ups.



- Draw in patchleads with colored pens.
- Draw or write control settings in the little white circles.

