

# DOEPFER

## Analog Synthesizer Kit

# DIY SYNTH

## User's Guide



© 2010 by  
**Doepfer Musikelektronik GmbH**  
Geigerstr. 13  
82166 Graefelfing  
Deutschland / Germany  
Phone: + 49 89 89809510  
Fax: + 49 89 89809511  
Web Site: [www.doepfer.com](http://www.doepfer.com)  
Email: [sales@doepfer.de](mailto:sales@doepfer.de)

## Important note

The DIY Synth kit is planned **for experienced users only** who are familiar with both electronics and analog synthesizers. It is definitely unsuitable for beginners ! For example we will not be able to offer the service to repair a customers assembly if it does not work as it should, or to make individual suggestions how to wire the board for special applications. We have to emphasize this fact very clearly in advance to avoid unsatisfied customers who will have problems getting their synth to run. If you are not sure if your skills are sufficient please return the DIY synth kit for money refund before you start to wire the board !

## Electrical safety / EMC compatibility

The **DIY Synth** kit is a so-called **OEM product** (OEM original equipment manufacturer) that cannot be used independently but has to be combined with additional electrical or electronical equipment to become a working device (suitable controls, switches, sockets, power supply, case/housing and so on). The manufacturer of **DIY Synth** kit does not know the final assembly of the complete device in which the **DIY Synth** kit is used as a part of the complete device. The final responsibility with regard to **electrical safety** and **electromagnetic compatibility** is up to the user who is assembling the complete device.

Please pay attention to the following items:

The **power supply** used in combination with the **DIY Synth** kit has to be a closed type. It is not allowed to use **open power supplies** with open **mains voltage** access (e.g. via mains lead, pcb tracks, electronic parts). For example the A-100 miniature power supply (A-100MNT) can be used.

As no radiation is expected due to the 100% analog low frequency circuits no **preventing measures** against **electromagnetic radiation** are met on the **DIY Synth** board. But it is impossible to estimate to what extend the **components added by the user** affect the **EMC properties** of the complete assembly (e.g. switching power supply). Therefore it is recommended to shield the complete device against electromagnetic radiation (incoming and outgoing). These demands are normally met by a closed metal case that covers the complete assembly. The metal case should be connected to GND of the **DIY Synth** kit.

## Warranty

- All connections have to be carried out in the off-state of the **DIY Synth** kit (i.e. without power supply)
- The **DIY Synth** kit is an electrostatic sensitive device. Avoid any electrostatic charges !
- Do not solder directly to any of the pin headers but use connectors to make the connections between the **DIY Synth** kit and your application.
- Use only a power supply that corresponds to the specifications given in this manual (i.e. +12V/GND/-12V).
- Applying a negative voltage less than  $-12\text{V}$  or a positive voltage beyond  $+12\text{V}$  at any of the inputs may destroy the circuit.
- Avoid short cuts while **DIY Synth** kit is powered (e.g. caused by metallic or conducting supports) !
- Ignoring any of these items will cause warranty loss !
- Return of the **DIY Synth** kit within the 2 weeks return time limit (valid only in Germany) is only possible if all these items have been met. **DIY Synth** kit that have been soldered or modified by the customer cannot be taken back.

***Electronic knowledge is required to install and operate the DIY Synth kit. If you are not sure whether your knowledge is sufficient please consult an expert. We cannot take back kits that became defective because of wrong installation or wrong connection of the controls or voltages. We also cannot take back modules or cables which have been soldered by the user.***

## Table of contents

Important note .....	2
Electrical safety / EMC compatibility .....	2
Warranty.....	3
Table of contents.....	4
Introduction.....	5
DIY Synthesizer kit (pc board schematics).....	7
Connecting controls and sockets .....	8
JP1: Power Supply .....	9
JP1: Power Supply .....	10
JP2: VCO and VCF connections .....	11
JP3: VCF, VCA and LFO connections.....	12
JP4: LFO and ADSR connections .....	13
JP5: LFO and ADSR connections .....	14
JP6: LFO, ADSR and Slew Limiter connections.....	15
JP7: VCO, VCF and VCA connections .....	16
JP10: Tempo-Option.....	17
Auxiliary terminals.....	17
Trimming potentiometers .....	17
Application Example.....	18
How to use the summing inputs.....	20
Attenuating signals .....	21
Generating manual controlled voltages .....	21
Variable resistors .....	21
Other applications of potentiometers .....	22
Controlling the ADSR parameters .....	22
Controlling the LFO frequency.....	23

## Introduction

The DIY synth kit is a low cost DIY kit to build a full-fledged analog synthesizer. The kit is made of an assembled and tested pc board that includes all that is necessary to build a standard analog synthesizer:

### VCO:

- Sawtooth output
- Rectangle output (with variable pulse width)
- Four frequency CV inputs (1V/Oct)
- Summing frequency CV input (to extend the number of CV inputs)
- Two PW/PWM CV inputs
- Summing PW/PWM input (to extend the number of PW/PWM CV inputs)
- Linear FM input
- Hard sync input

### VCF:

- Multimode filter
- lowpass, highpass and bandpass output (optional low-notch-highpass with external potentiometer)
- 12dB/oct slope
- Two frequency CV inputs
- Summing frequency CV input (to extend the number of CV inputs)
- Audio inputs
- Summing audio input (to extend the number of audio inputs)
- Manual resonance control
- Resonance up to self oscillation

### VCA:

- Exponential control scale
- CV inputs
- Summing CV input (to extend the number of CV inputs)
- Two audio inputs
- Summing audio input (to extend the number of audio inputs)
- Audio output

### ADSR:

- Connections for attack, decay, sustain and release controls
- Connections for range switch (3 ranges)
- Connections for LED display
- ADSR output

### LFO:

- Connections for frequency control (optional different controls for up/down time)
- Connections for range switch (3 ranges)
- Connections for LED display
- Triangle and rectangle outputs

### Slew Limiter:

- Connection for slew control
- Input
- Output

### Inverter/Mixer

- Input
- Summing input (to extend the number of inputs)
- Output
- Can be used for both audio or CV inverting or mixing

### Buffer

- Input
- Output

The kit is planned for customers who are familiar with electronic basics as the kit does not include the controls, switches, sockets, power supply and the case. These elements have to be added and wired by the. The customer can choose the desired size, shape, type and color of these elements (e.g. rotary potentiometers or faders, small 3.5 mm jack sockets or ¼" sockets or banana type, small or large knobs and switches and so on). Even the type of wiring is free: the range goes from a pre-wired standard synth (VCO-VCF-VCA type) up to a fully patchable small modular system. Two or more of the kits can be combined to obtain more VCOs, ADSRs, LFOs, VCAs or VCFs, e.g. to built a more complex pre-wired or modular synth. We think about a DIY Synth expansion board that may contain a noise generator, S&H, ring modulator, mixer, maybe Midi/USB interface and multi-effect unit, and other often used synthesizer units.

A **stabilized symmetrical 12V power supply** (i.e. -12V, GND, +12V) with at least 150 mA current is required.

The additional working time and required skills to build a working unit from the kit should not be underrated ! One should count at least on one weekend, even if you are an experienced hobbyist. To obtain all features about 25 potentiometers, 20 sockets and several switches have to be mounted into a suitable housing and wired faultless. We ask for your understanding that we cannot offer the service to troubleshoot a customer's assembly. The pc boards comes assembled, tested and adjusted (i.e. 1V/oct of the corresponding VCO CV inputs if the tempo option is used).

We do not offer complete units but only the pc board ! The pictures shown on our website are application examples for the DIY synth board. Assemblies like these are not available from us! Please don't ask !

A cable set is available as an option (two ribbon cables with 16 pins and five with 10 pins, each ~ 50 cm long, with assembled dual row female connectors on one side, the other side of each cable is open). It enables to connect/disconnect the DIY board without any soldering from the customers assembly. As standard dual row female connectors (IDC with 1/10" = 2.54 mm pitch) are used, experienced users will have no problems to assemble these cables themselves.

We offer also a **tempo option** which stabilizes the VCO while the temperature changes. The version without temperature compensation is fine for experimental sounds or drum/percussion applications where the exact 1V/oct scale of the VCO is not essential. For applications where the synth has to be played by a CV keyboard or Midi/CV interface the version with temperature control is recommended. This version has a good 1V/octave tracking over about 6 octaves in the range 40Hz ... 5kHz after ~ 20 minutes heating period.

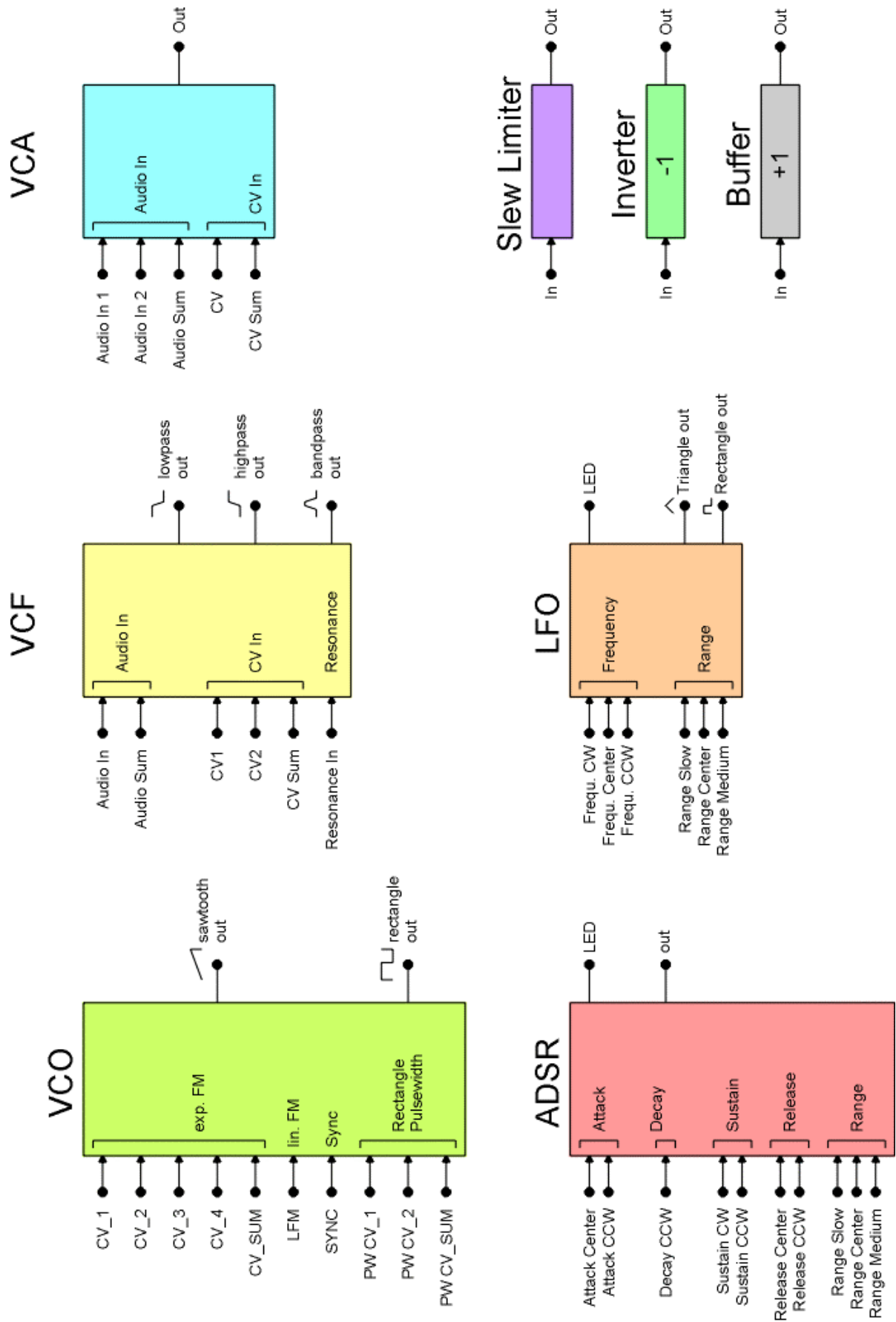

*DIY Synthesizer kit (pc board schematics)*

## Connecting controls and sockets

Please refer to the picture on the next page.

### Remarks for all connectors:

- Each of the pin headers JP1...JP7 has available a dot on the silk screen of the pc board that marks both pin #1 of the pin header and the colored wire of the ribbon cable, if a ribbon cable is connected via a female IDC connector to the pin header in question
- For each pin header two types of tables are available in this document:
  - One table shows the functions of the pins of the pin header (top view to the pin header). These diagrams are useful if it's necessary e.g. to measure a voltage directly at one of the pins or if the controls and sockets are directly soldered to the pin headers without the usage of IDC connectors and ribbon cables (not recommended).
  - Another table shows the functions of the wires if a ribbon cable is connected via a female IDC connector to the pin header in question. It is strictly recommended to use IDC connectors with ribbon cables to connect the controls and sockets.
  - The bold enframed rectangle of the ribbon cable table corresponds to the colored wire of the ribbon cable and to pin #1 of the pin header in question (and consequently to the dot on the silk screen of the pc board).
- All terminals labelled "GND" are connected on the pc board and are equivalent (i.e. they are shortened on the pc board). It is not necessary to connect each of the GND terminal. But sometimes it's useful to have GND at different points.
- For all summing inputs (VCO CV SUM, VCO PW CV SUM, VCF CV SUM, VCF AUDIO SUM, VCA CV SUM, VCA AUDIO SUM, INVERTER SUM) serial resistors have to be used ! Connecting a voltage directly to these inputs without a serial resistor may destroy the circuit. The recommended value for the serial resistors are mentioned at the description of each sum input.



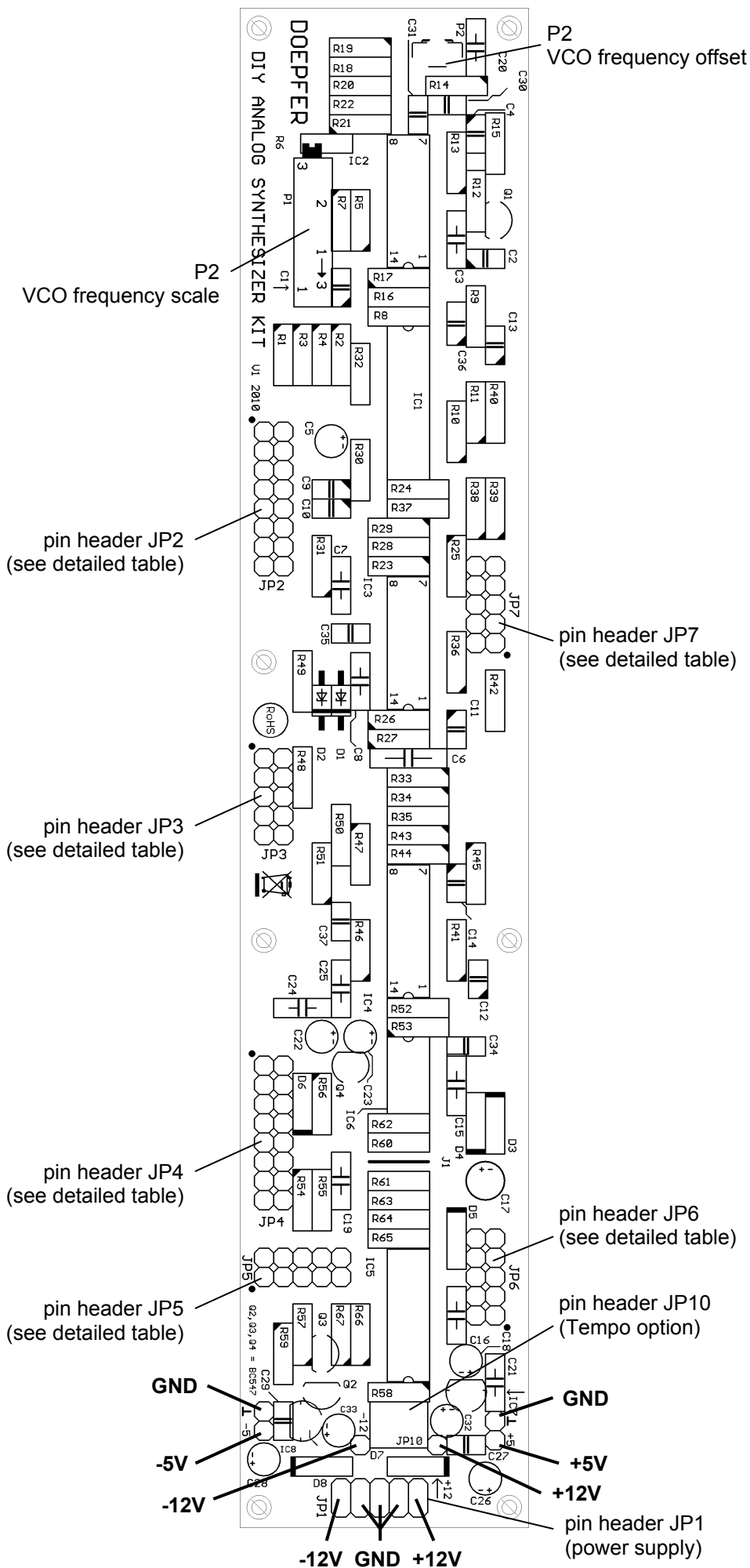

### **JP1: Power Supply**

A stabilized, symmetrical power supply with +12V, GND and -12V and a minimum of 150 mA (for both voltages +12V and -12V) is required. A high quality, stabilized supply is recommended as the power supply affects the stability of the modules (especially the VCO).

For example the power supplies of the A-100 modular system can be used (e.g. the miniature power supply A-100MNT with  $\pm 12\text{V}/200\text{mA}$ ).

The power supply is connected to JP1:

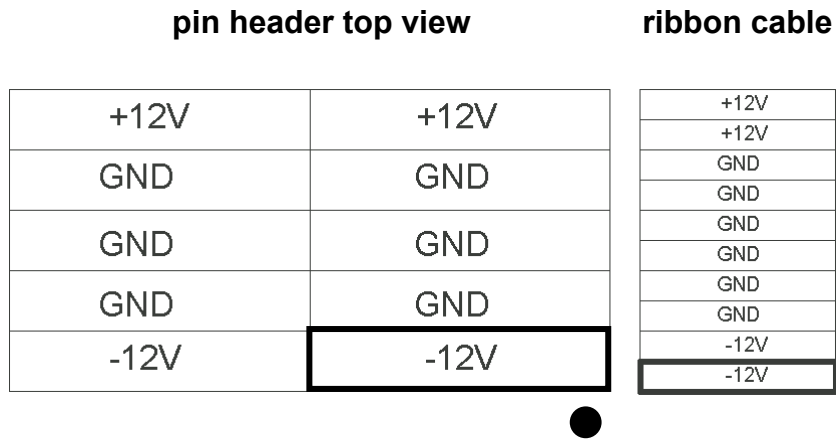

## JP2: VCO and VCF connections

JP2 contains some VCO and VCF terminals.

ribbon cable

pin header top view

VCO PW CV2	VCO PW CV2	VCO PW CV1
VCO PW CV1	VCO PW CV SUM	VCO RECT
VCO PW CV SUM	VCO CV1	VCO CV SUM
VCO RECT	VCO CV3	VCO CV4
VCO CV1	VCO CV2	VCO SAW
VCO CV SUM	VCO SYNC	GND
VCO CV3	GND	VCF RES IN
VCO CV4	VCF AUDIO IN	VCF BANDPASS
VCO CV2		
VCO SAW		
VCO SYNC		
GND		
GND		
VCF RES IN		
VCF AUDIO IN		
VCF BANDPASS		

Function	Explanation	Remark / Recommendation
VCO PW CV2	Control voltage input #2 for rectangle pulsewidth	Range about 0...+5V, recommended for PWM input (socket with attenuator)
VCO PW CV1	Control voltage input #1 for rectangle pulsewidth	Range about 0...+5V, recommended for PW manual control
VCO PW CV SUM	Control voltage summing input for rectangle pulsewidth	Required only if the number of CV inputs for pulsewidth has to be increased, serial resistor 100k recommended for 0...+5V
VCO RECT	VCO rectangle output	about 5V level (+/- 2.5V), DC coupled
VCO CV1	Control voltage input #1 for VCO frequency	Sensitivity: 1V/octave, e.g. for manual frequency control
VCO CV SUM	Control voltage summing input for VCO frequency	Required only if the number of frequency CV inputs is not sufficient, serial resistor 100k required for 1V/octave
VCO CV3	Control voltage input #3 for VCO frequency	Sensitivity: 1V/octave, e.g. for CV input socket
VCO CV4	Control voltage input #4 for VCO frequency	Sensitivity: 1V/octave, e.g. for CV input socket
VCO CV2	Control voltage input #2 for VCO frequency	Sensitivity: 1V/octave, e.g. for FM input (socket with attenuator)
VCO SAW	VCO sawtooth output	about 6V level (+/- 3V), AC coupled
VCO SYNC	Hard Sync Input	Negative slope causes a sawtooth reset (rectangle or sawtooth input required, min. level 5V required)
2 x GND		
VCF RES IN	VCF resonance connector	Has to be wired to the VCF Bandpass output via attenuator (resonance control, recommended value 50...100k linear)
VCF AUDIO IN	VCF audio input	Usually connected to one of the VCO outputs via attenuator (for clipping/distortion control), if both VCO waveforms have to be mixed the VCF AUDIO SUM has to be used (see JP7)
VCF BANDPASS	VCF bandpass Output	Usually connected to a socket labelled "VCF Bandpass", also required for resonance control (VCF RES IN)

### JP3: VCF, VCA and LFO connections

JP3 contains some VCF, VCA and LFO terminals.

**ribbon cable**

**pin header top view**

LFO RECTANGLE
VCF LOWPASS
VCF CV2
VCF CV1
VCA CV
LFO POT CCW
LFO POT CENT
LFO POT CW
GND
GND

LFO RECTANGLE	VCF LOWPASS
VCF CV2	VCF CV1
VCA CV	LFO POT CCW
LFO POT CENT	LFO POT CW
GND	GND

Function	Explanation	Remark / Recommendation
LFO RECTANGLE	LFO rectangle output	about 10V level (+/- 5V)
VCF LOWPASS	VCF lowpass Output	Usually connected to a socket labelled "VCF Lowpass", can be connected additionally to a potentiometer for lowpass/notch/ highpass control
VCF CV2	Control voltage input #2 for VCF frequency	Sensitivity: roughly 1V/octave, e.g. for FM input (socket with attenuator, e.g. normalled to ADSR output)
VCF CV1	Control voltage input #1 for VCF frequency	Sensitivity: roughly 0.5V/octave, e.g. for manual frequency control
VCA CV	Control voltage input for VCA loudness	Range about 0...+5V, usually connected to a socket labelled "VCA CV In" with attenuator which is normalled to the ADSR output, if more VCA CV inputs are required VCA CV SUM has to be used (see JP7)
LFO POT CCW	CCW terminal of the LFO frequency control	Connected to LFO control (1M log recommended)
LFO POT CENT	Center terminal of the LFO frequency control	
LFO POT CW	CW terminal of the LFO frequency control	
GND		
GND		

## JP4: LFO and ADSR connections

JP4 contains some LFO and ADSR terminals.

ribbon cable

Pin header top view

LFO SW MEDIUM	LFO SW MEDIUM	LFO TRIANGLE
LFO TRIANGLE	LFO SW LOW	LFO SW COMMON
LFO SW LOW	GND	GND
LFO SW COMMON	GND	ATTACK CCW
GND	ATTACK CENTER	SUSTAIN CW
GND	DECAY CCW	SUSTAIN CCW
ATTACK CCW	ADSR LED	RELEASE CENT.
ATTACK CENTER	GND	GATE
SUSTAIN CW		
DECAY CCW		
SUSTAIN CCW		
ADSR LED		
RELEASE CENTER		
GND		
GATE		

Function	Explanation	Remark / Recommendation
LFO SW MEDIUM	LFO range switch medium position	Usually connected to the terminal of a 1-0-1 toggle switch
LFO TRIANGLE	LFO triangle output	about 10V level (+/- 5V)
LFO SW SLOW	LFO range switch low position	Usually connected to the terminal of a 1-0-1 toggle switch
LFO SW COMMON	LFO range switch common terminal	Usually connected to the center terminal of a 1-0-1 toggle switch
GND		
GND		
GND		
ATTACK CCW	CCW terminal of the ADSR attack control	Usually connected to the CCW terminal of the attack control (1M log)
ATTACK CENTER	Center terminal of the ADSR attack control	Usually connected to the center terminal of the attack control (1M log)
SUSTAIN CW	CW terminal of the ADSR sustain control	Usually connected to the CW terminal of the sustain control (50k lin)
DECAY CCW	CCW terminal of the ADSR decay control	Usually connected to the CCW terminal of the decay control (1M log)
SUSTAIN CCW	CCW terminal of the ADSR sustain control	Usually connected to the CCW terminal of the sustain control (50k lin)
ADSR LED	ADSR LED display	Usually connected to the anode (plus) of a LED. The cathode of the LED is connected to GND.
RELEASE CENTER	Center terminal of the ADSR release control	Usually connected to the center terminal of the release control (1M log)
GND		
GATE	ADSR gate input	Usually connected to the gate input socket, min. +5V gate level required, the socket can be normalled e.g. to the rectangle output of the LFO (LFO triggering of the ADSR)

### JP5: LFO and ADSR connections

JP5 contains some ADSR, Buffer and Inverter/Mixer terminals.

**pin header top view**

**ribbon cable**

BUFFER OUT	BUFFER IN	BUFFER OUT
ADSR OUT	INV IN	ADSR OUT
INV SUM	INV OUT	INV IN
GND	RELEASE CCW	INV SUM
GND	<b>GND</b>	INV OUT
		GND
		RELEASE CCW
		GND
		<b>GND</b>



Function	Explanation	Remark / Recommendation
BUFFER OUT	Output of the buffer	Usually connected to the center terminal of the ADSR decay control for best ADSR operation
BUFFER IN	Input of the buffer	Usually connected to the center terminal of the ADSR sustain control for best ADSR operation
ADSR OUT	ADSR output	Typ. 0...+8V level, usually connected to the ADSR output socket, can be normalled to the FM/AM inputs of the VCF and VCA
INV IN	Inverter input	Can be used to invert a signal (e.g. ADSR), if the INV SUM is used the inverter unit can be used also for mixing of CV or audio signals
INV SUM	Inverter summing input	Required if the inverter should be used as a mixer, serial resistor(s) 100k recommended for same sensitivity as INV IN
INV OUT	Inverter output	
GND		
RELEASE CCW	CCW terminal of the ADSR release control	Usually connected to the CCW terminal of the release control (1M log)
GND		
GND		

**JP6: LFO, ADSR and Slew Limiter connections**

JP6 contains some ADSR, LFO and Slew limiter terminals.

**pin header top view**

**ribbon cable**

LFO LED	GND	LFO LED
ADSR SW LOW	ADSR SW COMM	GND
ADSR SW MED	GND	ADSR SW LOW
GND	GND	ADSR SW COMM
SLEW IN	<b>SLEW OUT</b>	ADSR SW MEDIUM
		GND
		GND
		GND
		SLEW IN
		<b>SLEW OUT</b>



Function	Explanation	Remark / Recommendation
LFO LED	LFO LED display	Usually connected to a dual color LED. The second terminal of the LED is connected to GND (e.g. the following wire).
GND		e.g. for the second terminal of the LFO LED
ADSR SW SLOW	ADSR range switch low position	Usually connected to the terminal of a 1-0-1 toggle switch
ADSR SW COMM	ADSR range switch common terminal	Usually connected to the center terminal of a 1-0-1 toggle switch
ADSR SW MEDIUM	ADSR range switch medium position	Usually connected to the terminal of a 1-0-1 toggle switch
GND		
GND		
GND		
SLEW IN	Input of the slew limiter	Usually connected to the slew source (e.g. CV for VCO) via a 1M log potentiometer for slew control
SLEW OUT	Output of the slew limiter	Can be connected e.g. to one of VCO CV inputs to have available the portamento function for this input

## JP7: VCO, VCF and VCA connections

JP7 contains some VCO, VCF and VCA terminals.

pin header top view

VCA AUDIO 1	VCA AUDIO 2
VCO LIN FM	VCA AUDIO SUM
VCF HIGHPASS	VCA CV SUM
VCF AUDIO SUM	GND
VCF CV SUM	VCA OUT

ribbon cable

VCA AUDIO 1
VCA AUDIO 2
VCO LIN FM
VCA AUDIO SUM
VCF HIGHPASS
VCA CV SUM
VCF AUDIO SUM
GND
VCF CV SUM
VCA OUT

Function	Explanation	Remark / Recommendation
VCA AUDIO IN 1	VCA audio input 1	Usually connected to a socket that is normalised to one of the VCF outputs (usually low pass or to the lowpass/notch/highpass control)
VCA AUDIO IN 2	VCA audio input 2	Usually connected to a socket that is normalised to one of the other VCF outputs or directly to one of the VCO (bypassing the VCF)
VCO LIN FM	VCO linear FM input	Allows linear control of the VCO frequency (down to zero Hz because it's DC coupled), the characteristic is inverted (i.e. increasing the control voltage at this input reduces the frequency and vice versa, the VCO stops when about +1.2 V are applied), usually connected to a socket labelled "linear FM" with attenuator
VCA AUDIO SUM	VCA audio summing input	Can be used to add audio inputs to the VCA, required only if the number of VCA audio inputs is not sufficient, serial resistor 47k required for same sensitivity as VCA AUDIO IN 1/2
VCF HIGHPASS	VCF highpass Output	Usually connected to a socket labelled "VCF Highpass", can be connected additionally to a potentiometer for lowpass/notch/ highpass control
VCA CV SUM	Control voltage summing input for VCA loudness	Required only if one VCA CV input is not sufficient, serial resistor 220k required for same sensitivity as VCA CV (see JP3)
VCF AUDIO SUM	VCF audio summing input	Can be used to add audio inputs to the VCF, required only if the number of VCF audio inputs is not sufficient, serial resistor 47k required for same sensitivity as VCF AUDIO IN (see JP2)
GND		
VCF CV SUM	Control voltage summing input for VCF frequency	Required only if the two VCF CV inputs of JP3 are not sufficient, serial resistor 100k required to obtain roughly 1V/octave (or ~ 47k for 0.5V/octave)



VCA OUT	VCA Output	Usually connected to a socket labelled "VCA Out", which is normally the final output of the synthesizer and connected to the audio mixer
---------	------------	--

### ***JP10: Tempo-Option***

If the tempo option is used IC1 has to be removed and replaced by the tempco option. That's nothing but the former IC1 expanded by a small temperature controlled oven that is glued to the circuit. The oven heats up the the circuit IC1 to a fixed temperature which is clearly above the usual room temperature (sorry - the tempo option will probably not work in the Death Valley or in the Sahara desert ☺).

The tempo option is connected to JP10.

### ***Auxiliary terminals***

Near the power supply connector JP1 some auxiliary terminals are available (please refer to the picture on page 9 for the corresponding positions):

- +5V / GND (JP8): output of an +5V voltage regulator (derived from +12V)
- -5V / GND (JP9): output of an -5V voltage regulator (derived from -12V)
- +12V (JP11): nothing but a terminal connected to +12V
- -12V (JP12): nothing but a terminal connected to -12V

These terminals can be used whenever a fixed voltage is required (e.g. for potentiometers that are used to generate manually controlled voltages e.g. for VCO tuning, VCF frequency, VCA loudness or others). If a higher voltage range is required (e.g. for manual VCF frequency control) the "high voltage" terminal +12V can be used. If a smaller voltage range is required the "small voltage" terminal +5V can be used (same applies to -12V and -5V). The voltages appearing at the +5V and -5V terminal have the advantage that they are nearly independent of possible voltage changes of the +/-12V supply. Consequently they should be used for VCO control applications.

### ***Trimming potentiometers***

Trimming potentiometer P1 is used to adjust the 1V/octave scaling of the CV inputs of the VCO (CV1...CV4 of JP2). If the tempo option is used the board should be powered at least 20 minutes before this parameter is adjusted. For example a control voltage with the values 0.0 V / 1.0V / 2.0V / 3.0V / 4.0V /5.0V is applied to one of the 1V/oct CV inputs of the VCO. The CV can be supplied e.g. from a Midi-to-CV interface (e.g. A-190-2) or a CV keyboard (e.g. A-100CGK). P1 is adjusted so that the 1V intervals of the CV correspond exactly to octave intervals. If a frequency counter is available the frequencies can be measured, e.g. 32 / 64 / 128 / 256 / 512 / 1024 / 2048 Hz. But usually the human ear is the best frequency counter.

Trimming potentiometer P2 is used to adjust the frequency offset of the VCO (i.e. the lowest frequency if all VCO CV inputs are 0V). It's up to the user which frequency is chosen. Usually a "C" is chosen when all frequency controls (e.g. coarse and fine tuning) are in the center positions. The corresponding "C" frequencies are ~ 65 Hz or ~33Hz (one octave less).

## Application Example

These symbols for electronic parts are used in the following:

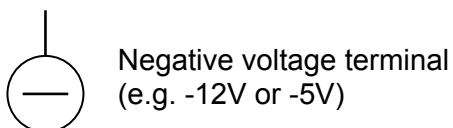
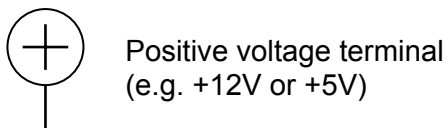
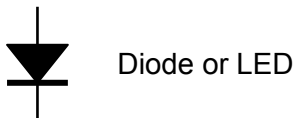
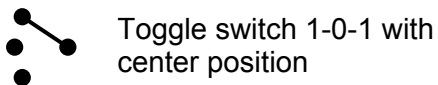
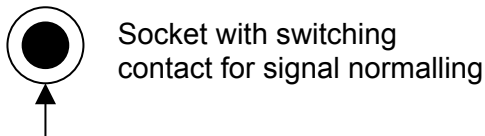
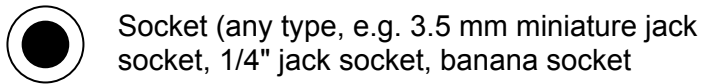
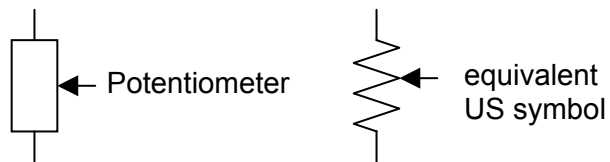
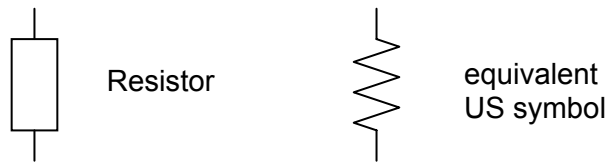

The picture on the next page shows the complete schematics (including all controls, sockets, switches and LEDs) for a typical application of the DIY Synthesizer board. On the pages following the diagram the wiring is described in detail.

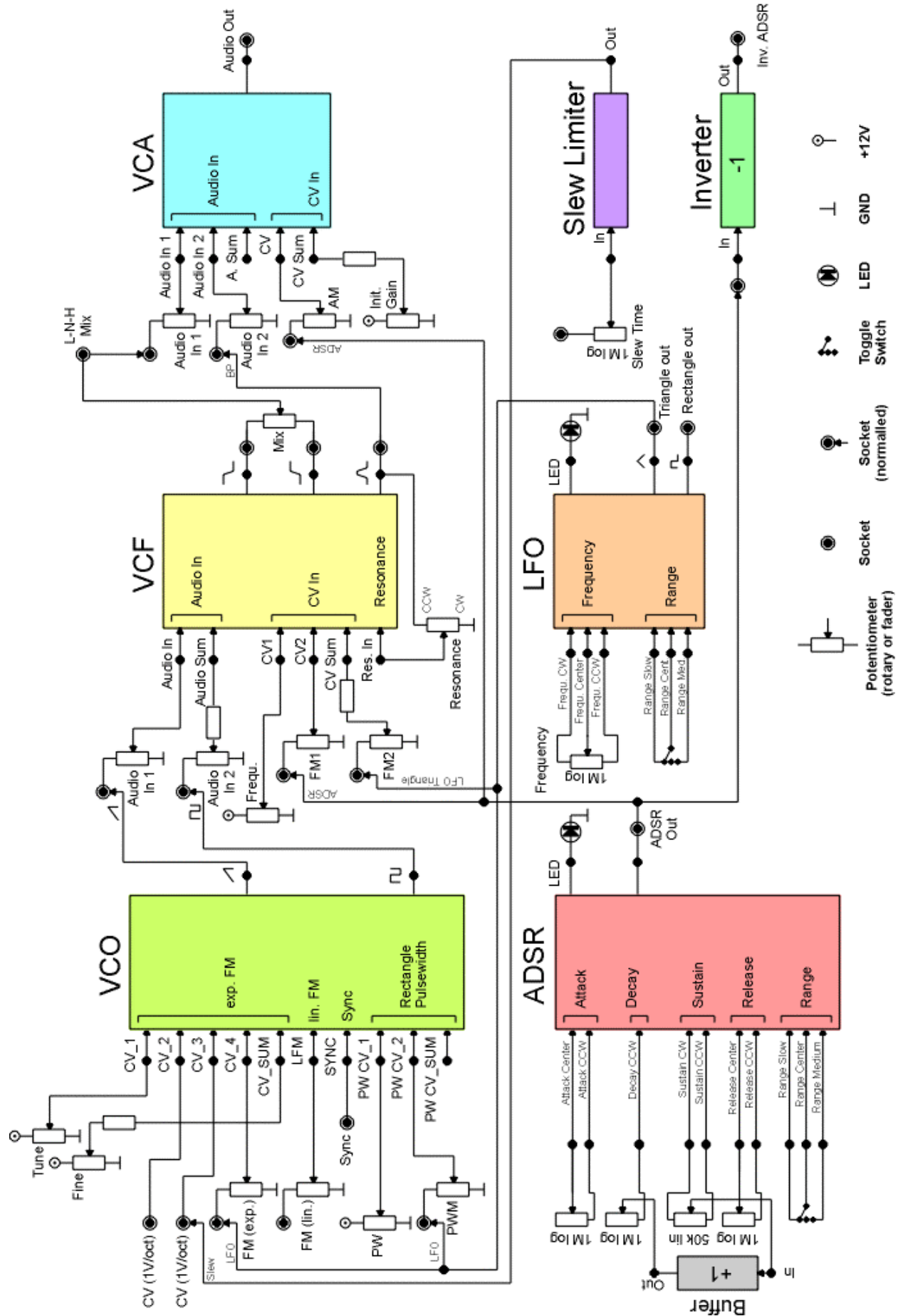

## How to use the summing inputs

Each voltage controlled parameter (e.g. VCO frequency or VCF frequency) has at least one control voltage (CV) input available. If the number of CV inputs is not sufficient more inputs can be added. For this we have to take a look at the input circuit used for all types of control voltage summing applications. It's nothing but the standard inverting operational amplifier circuit:

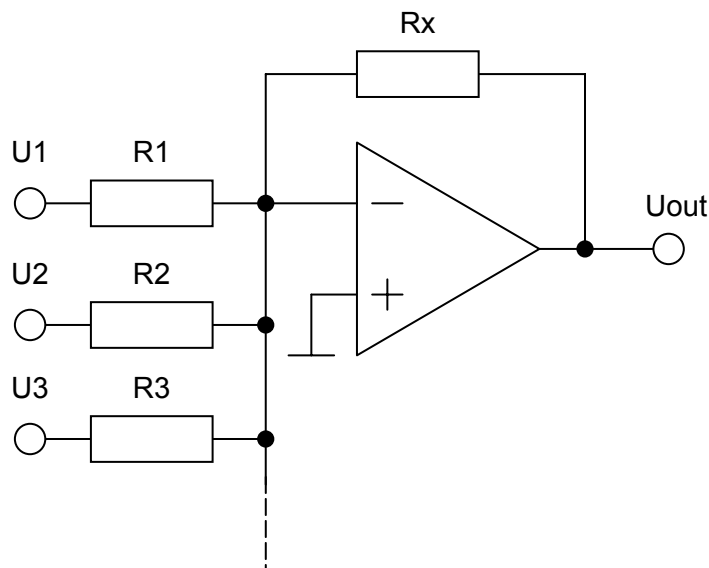

The voltage appearing at the output is:

$$- U_{out} = U_1 (R_x/R_1) + U_2 (R_x/R_2) + U_3 (R_x/R_3) + \dots$$

This circuit can be used to add several voltages (U1, U2, U3 ...) with selectable sensitivity (defined by R1, R2, R3 ...). Provided that all resistors have the same value (e.g. 100k) the output voltage is nothing but

$$U_{out} = -(U_1 + U_2 + U_3 + \dots)$$

This type of circuit is used whenever control voltages or audio signals have to be added (or mixed) in the DIY Synthesizer. In addition the summing node (i.e. the inverting input of the operational amplifier) is available as a separate terminal. This allows to expand the number of CV or audio inputs if the available inputs are not sufficient. For this the additional input has to be connected to the summing node via a suitable serial resistor (R4, R5 ...). Do not connect a voltage directly to the summing node! This may destroy the operational amplifier.

In the tables JP2...JP7 that explain the functions of the pin headers the value of the required serial resistor is mentioned. If the input in question has to be more sensitive the value of the serial resistor has to be reduced (e.g. 51k or 47k instead of 100k for doubling the sensitivity). If the input in question has to be less sensitive the value of the serial resistor has to be increased (e.g. 1M instead on 100k). A typical application are several tuning inputs for the VCO frequency. A course tune control may be connected e.g. via 100k to the summing node, a fine tune control via 2M2. In this case the fine tune is about 20 times more sensitive than the coarse control.

## Attenuating signals

In many applications it is necessary to attenuate a signal (e.g. to adjust the ADSR modulation amount of the VCF or the audio signal input of the VCF). The following simple circuit is recommended to attenuate a signal:

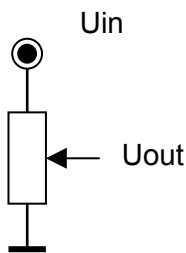

At the output of this circuit ( $U_{out}$ ) appears the attenuated input signal ( $U_{in}$ ). A typical value for the potentiometer is 50...100k. Depending upon the application a linear or logarithmic potentiometer type can be used. For audio signals usually logarithmic potentiometers and for CV attenuation linear ones are used. But this is not obligatory. Even for CV attenuation (e.g. for the VCO or VCF FM) a logarithmic potentiometer may be useful.

## Generating manual controlled voltages

For some applications it is necessary to generate a manually controlled voltage (e.g. for VCO tuning, manual PW control, manual VCF frequency control, initial gain of the VCA). For this a modified version of the attenuator circuit above is used. The arbitrary input signal  $U_{in}$  is simply replaced by a fixed voltage:

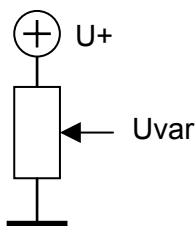

This circuit generates a voltage in the range  $0V...+U$ .  $+U$  can be e.g. +12V or +5V. For VCO tuning applications +5V is recommended (auxiliary terminal JP8) because this voltage is independent of possible voltage changes of the +12V supply. A typical value for the potentiometer is 50...100k. Usually a linear potentiometer is used.

## Variable resistors

Potentiometers can be used also as variable resistors (e.g. for the ADSR parameters attack, decay, release or for controlling the slew time of the slew limiter). For this only two terminals of the potentiometer are used: the center terminal and the CCW or CW terminal. The unused terminal can be connected to the center terminal. The following circuit is recommended for this application:

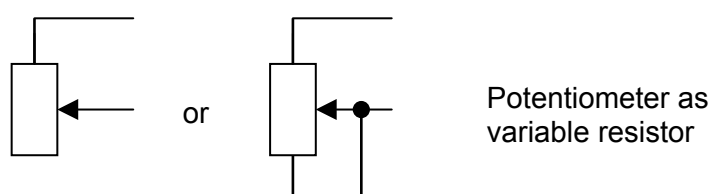

*Application idea:* In each circuit a variable resistor can be replaced by an LDR (light depending resistor). For an LDR the resistance value depends upon the illumination and ranges from some MOhm (dark state) to some hundred Ohm (bright illuminated state). For example the decay or slew time can be controlled by an LDR that is shadowed by the hand (instead of or additional to the usual manual control). Even the LFO or ADSR LED can be used to illuminate the LDR causing a parameter change that depends upon the LED brightness. In addition the hand can be used to shadow the LED from the LDR.

### Other applications of potentiometers

Another application is the usage of a potentiometer to adjust the shares of two signals, e.g. lowpass and highpass of the VCF (or sawtooth and rectangle of the VCO):

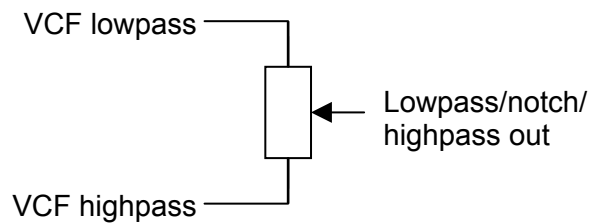

In the upper position the lowpass appears at the center terminal of the potentiometer, in the lower position the highpass. In between a mixture of lowpass and highpass appears and in the center position of the control one obtains a notch filter. A linear 10...100k potentiometer is recommended. For higher resistance values of the potentiometer an additional buffer is recommended to avoid level changes while operating the control (center terminal of the potentiometer connected to buffer input).

### Controlling the ADSR parameters

The ADSR parameter Attack and Release are controlled by variable logarithmic 1M resistors as mentioned on the preceding page. These two potentiometers are simply connected to the terminals ATTACK CCW, ATTACK CENTER and RELEASE CENTER of JP4, and RELEASE CCW of JP5. CCW is the counterclockwise terminal, CENTER the center terminal.

The potentiometers controlling Sustain and Decay are connected in that way:

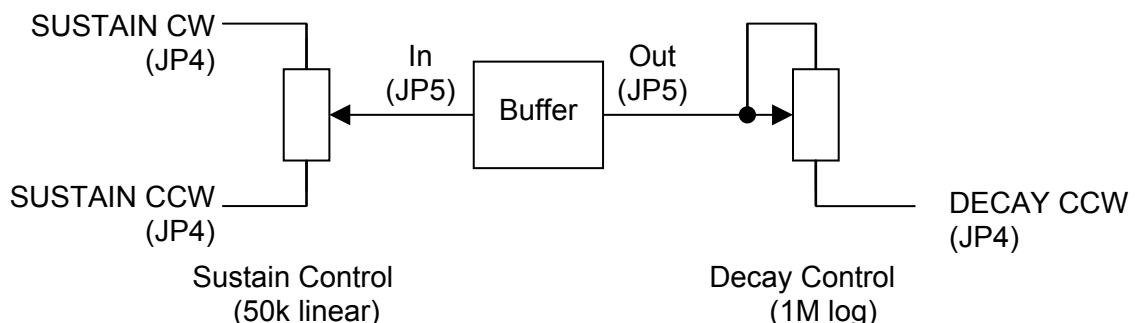

For a better ADSR operation it is recommended to insert the buffer between the center terminal of the sustain control and the center terminal of the decay control. The ADSR will even work without the buffer. But then the envelope waveform is not as expected for short decays as the 50k sustain potentiometer is loaded during the decay state.

## Controlling the LFO frequency

The LFO frequency is controlled by a potentiometer connected to the terminals LFO POT CCW, LFO POT CENT and LFO POT CW of JP3:

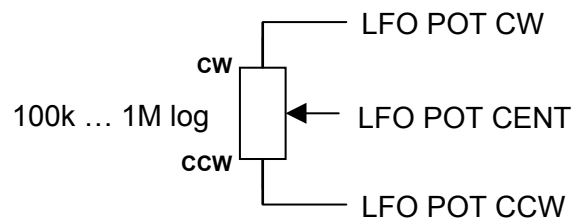

Another type of LFO control is the usage of separate controls for the rising and falling slope. In this case the wiring of the LFO pins is a bit different:

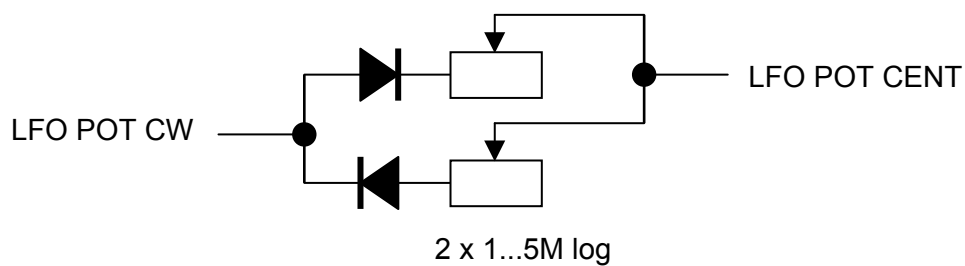

In this case the terminal LFO POT CCW is unused.

It is also possible to switch between both version of LFO control by adding a switch between the terminal LFO POT CENT and the two circuits.

**DOEPFER**  
*MUSIKELEKTRONIK*  
**www.doepfer.com**