

MTC64 Relay Board

Relay Expansion Board for MTC64 Main Board

Installation and User's Manual

© 2006 by Doepfer Musikelektronik

Important Notes

- *Dangerous voltages may appear at the pc board, electronic parts and wires during operation if the relays are used to switch voltages beyond 40V.*
- *Because of electrical safety installation, wiring and operation of the MTC relay board has to be carried out by qualified personnel only that is familiar with all safety rules valid in the country where the MTC relay board is installed.*
- *Not qualified personell is not allowed to install and run the MTC relay board!*
- *If you are not sure if your knowledge is sufficient to install and run the MTC relay board do not install and operate the device.*
- *The user has to read the installation manual carefully and follow all instructions in the manual meticulously !*
- *If the relays are used to switch voltages beyond 40V the complete construction has to be mounted into an isolating case. It has to be impossible to touch any part that may lead any voltage beyond 40V (including cables, electronic parts, connectors, pcb tracks, wires, cables and so on).*
- *Operation of the MTC relay board outside such a housing is strictly forbidden if voltages beyond 40V are used!*
- *In case that a metal housing is used it has to be connected to earth/shield.*
- *Connecting and wiring the boards has to be carried out without voltage applied to the boards. Therefore the board has to be disconnected completely from the power supply during any work at the boards.*
- *For all connections and wiring connectors and cables have to be used that are suitable and licenced for the voltage and current in question.*
- *Because of heat emmission the complete construction has to be cooled to avoid overheating. Possibly a housing with ventilation slits or an additional fan has to be used.*
- *The complete construction must never be operated outdoors but only in dry, closed rooms. Never use it in a humid or wet environment nor near inflammables.*
- *No liquids or conducting materials must get into the construction. If this should happen the board must be disconnected from power immediately and be examined, cleaned and eventually be repaired by a qualified person.*
- *Never subject the construction to temperatures above +50°C or below -10°C. Before operation the device should have a temperature of at least 10°C.*
- *Do not place the device into direct sun light. Do not install the instrument near heat sources.*
- *Never use the device in the immediate proximity of other electronic devices (e.g. monitors, computers) since this could create disturbances within both devices.*
- *The terminal screws have to be tightened very fast to avoid slipping out of the cables.*

- ***The pc boards has 3 mm mounting holes that can be used to mount the board to the bottom of the case with screws, washers, nuts and spacers. If a plastic case is used even plastic screws/washers/nuts/spacers have to be used. In case of metallic screws/washers/nuts dangerous voltages may appear at these parts outside the plastic case. If a (grounded) metallic case is used even metallic screws/washers/nuts/spacers are allowed.***
- ***The MTC64 main board has to be adjusted to the desired Midi channel, note number range (resp. program change number range), mode (note or program change) and polarity before the case that contains both MTC relay board(s) and the corresponding main board is closed. Please refer to the user's manual of MTC64 main board for details.***
- ***If the outputs of the MTC relay board behave the other way round the polarity of the MTC64 outputs have to be changed.***
- ***The MTC64 Relay Board may only be used for the purpose described in this operating manual. Due to safety reasons, the device must never be used for other purposes not described in this manual. If you are not sure about the intended purpose of the instrument please contact an expert.***

The MTC Relay Board is an expansion board for the **universal MIDI control electronics MTC64**. It has available 16 relays. Each relay is able to switch a max. voltage of 100V and a max. current of 1A. For example lamps, magnets, motors, laser beams but even audio signals can be switched on/off by Midi note on/off or program change messages.

These are the most important features:

- 16 relays (reed relays)
- max. switching voltage 100V
- max. switching current 1A for each relay
- relay connections via screw terminals
- 16 LED controls that indicate the relay states
- up to four MTC relay boards can be connected to one MTC64 main board
- connection between MTC relay boards and MTC64 main board is established via one 10 pin ribbon cable leading from the main board to all relay boards, and a 16 pin ribbon cable between main board and relay board (one for each relay board).
- the 16 pin ribbon cable is included with the relay board.
- the 10 pin ribbon cable is included only if the relay board(s) is/are ordered together with the MTC64 main board. Otherwise the 10 pin ribbon cable has to be ordered separately. In this case please specify how many relay boards have to be connected to the main board (because of the length and number of female connectors of the 10 pin ribbon cable)
- cables for the wiring of the relay contacts are not included
- If an older MTC64 main board is used the integrated circuits labelled CD4094 have to be replaced by 74HC4094 (valid only for old MTC64 main boards manufactured before January 2005, in case of orders of main boards in combination with relay boards the main boards are already equipped with 74HC4094)
- The sketch on page 4 shows the wiring of the MTC Relay Board(s) with the MTC64 main board

Connections

JP2 (10 pin connector)

This pin header is connected to JP5 on the MTC64 main board and carries GND and +5V (i.e. the power supply for the relay board). For the connection a 10 pin ribbon cable with a female connector on each side is used. If two or more MTC relay boards are used in combination with one MTC64 main board this connection has to be carried out parallel (i.e. GND and +5V for all boards). For this a special 10 pin ribbon cable has to be used with the corresponding number of female connectors. A cable with 3 connectors is required for 2 relay boards, a cable with 4 connectors is required for 3 relay boards and a cable with 5 connectors is required for 4 relay boards. If several MTC relay boards are ordered together a suitable cable is enclosed. If the relay boards are ordered one after another the special cable has to be ordered in addition (please specify the number of female connectors and the distances between the connectors).

Pay attention to the correct polarity of the connection: the wire of the ribbon cable that leads +5V (this side of the connector is labelled "+5V" on the MTC64 main board) has to point down (i.e. direct to the integrated circuits on the relay board). If the 10 pin cable is connected in the wrong way GND and +5V are shortened. This may destroy the power supply of the MTC64 main board!

JP1 (16 pin connector)

This pin header is connected to one of the pin headers JP1 (range 1...16), JP2 (range 17...32), JP3 (range 33...48) or JP4 (range 49...64) on the MTC64 main board. For the connection a 16 pin ribbon cable with a female connector on each side is used. Up to four MTC relay boards can be combined with one MTC64 main board. Connecting the cable in the wrong to JP1...JP4 on the MTC64 main board will cause no damage. Only the sequence of the outputs will be mixed up.

X1 ... X16 (2 pin screw terminals)

These are the terminals for the contacts of the 16 relays. Each 2 pin terminal corresponds to one relay. The contacts can be treated like normal on/off switches (controlled by Midi note messages). The max. voltage is 100V and the max. current is 1A for each relay.

screw terminals
(relay contacts)

LED controls

10 pin connector JP2
→ to JP5 MTC64 main board

(corresponding
markings to those of
JP5 at the main board)

16 pin connector JP1
→ to JP1 or JP2 or JP3 or JP4
MTC64 main board

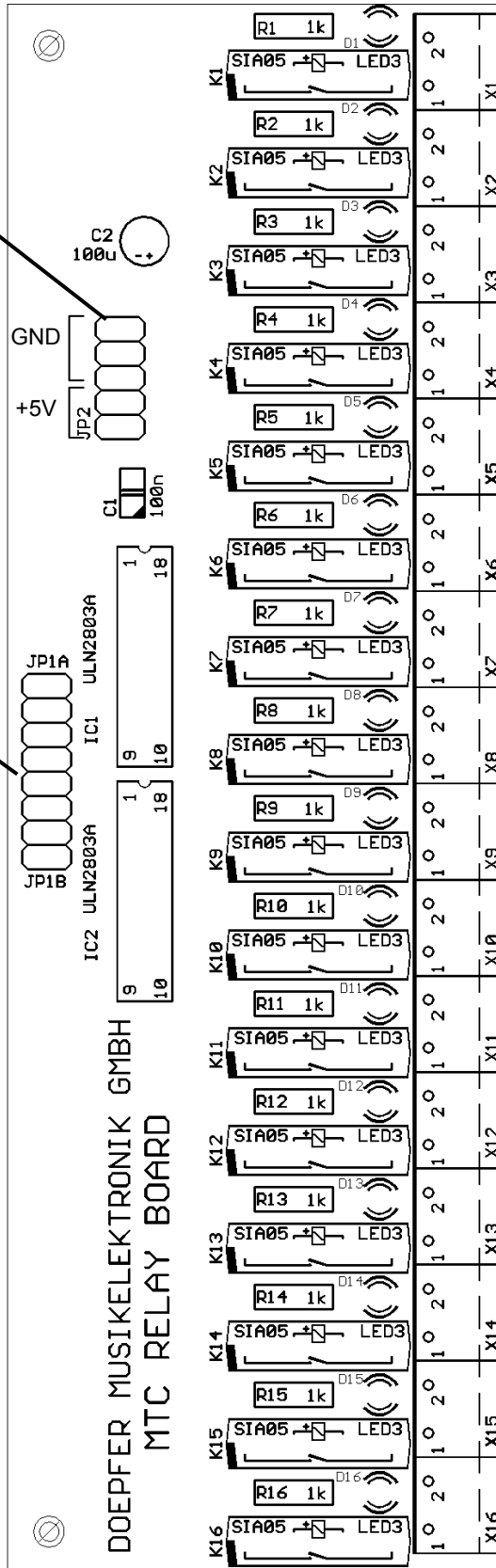

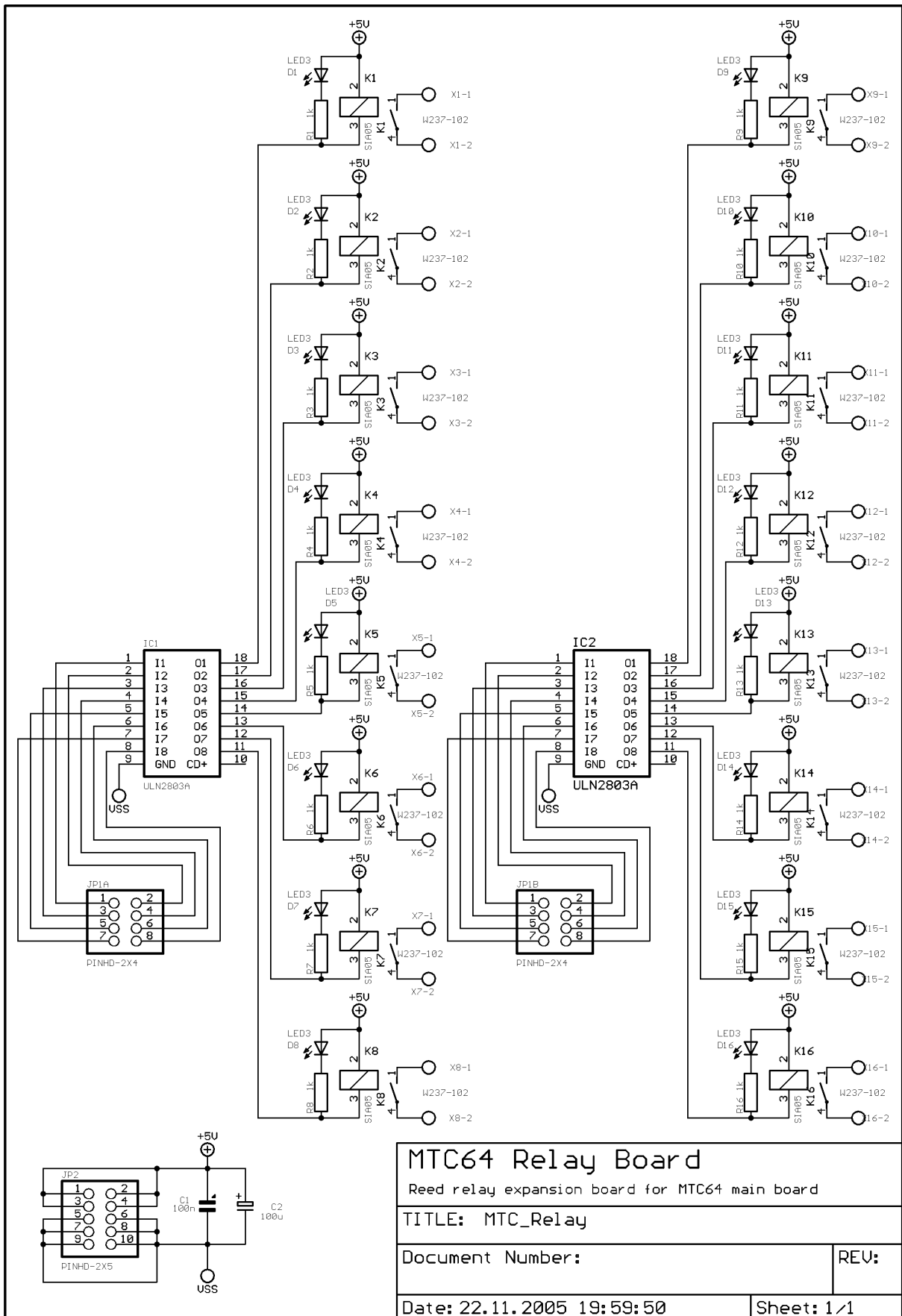

Schematics MTC Relay Board
 © 2006 by Doepfer Musikelektronik

Check list

If the MTC relay board does not work at the first go please check these points:

- Does the MTC64 main board alone work correctly ? Check especially the correct Midi channel, note/program change range, mode and polarity. Please refer to the user's manual of the MTC64 main board for details and do the basic tests with a LED described on page 13.
- Is the MTC64 main board equipped with 74HC4094 (instead of CD4094) ? This could happen only if an old MTC64 main board is used. For orders of MTC relay boards together with MTC64 main boards this cannot happen.
- If the outputs of the MTC relay board behave the other way round the polarity of the MTC64 outputs has to be changed (Jumper 5 / JP7 on main board).
- Are all ribbon cable connections between main board and relay board carried out in the right way and is the polarity of the 10 pin ribbon cable correct ?
- Are the relay terminals (X1...X16) connected in the right way ?

DOEPFER
MUSIKELEKTRONIK

www.doepfer.com