



grendel

FORMANT FILTER

Patching Guide

2.0.1

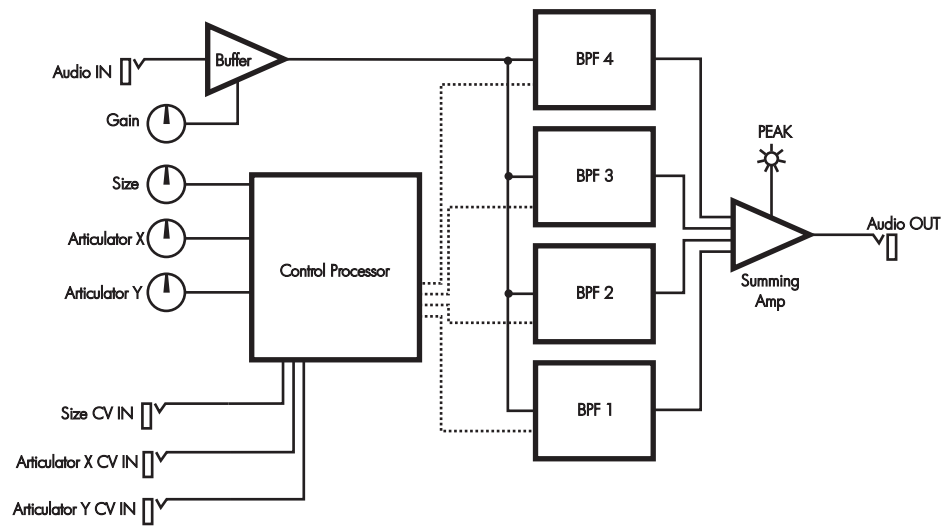

Patch 1

Two Axis Vowel Synthesis with MIDI-CV Converter

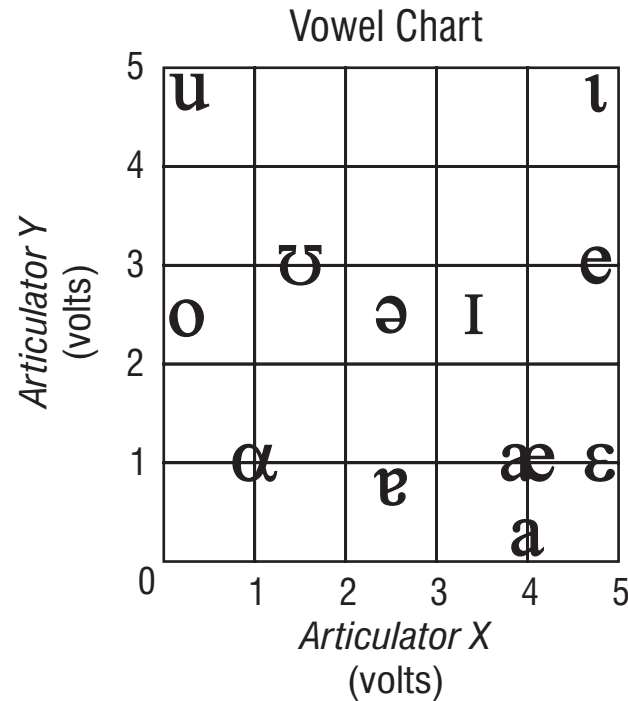
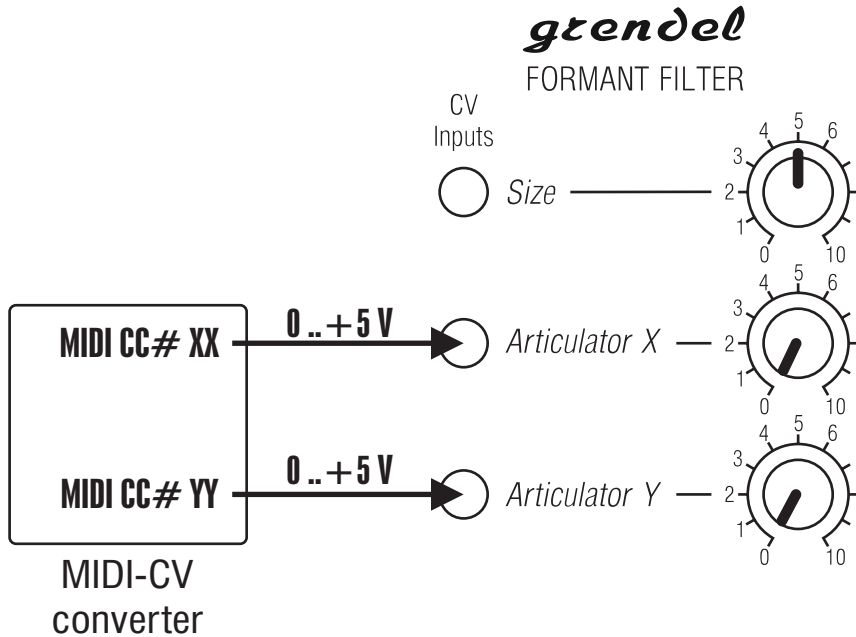

Pronunciation Guide *

u	BOOT
ɪ	FREE
ʊ	HOOK
ɛ	PLAY
ɪ	BIT
ɔ	GO
ə	TINA
ɛ	BED
ɑ	STACK
ɑ	HOT
æ	CAT
ɹ	NUT

* N. American English

If the MIDI-CV converter's output range is 0.. +5 volts, set the Articulator X and Articulator Y knobs to the zero mark. This provides correct offset bias for full range of control.

If using a 1V / octave CV output, set the Articulator's knob to the zero mark. Use the bottom 5 octaves of MIDI notes to control the formant filter.

If the MIDI-CV converter has bipolar output, such as Pitch Bend, set the Articulator knob to the 5 mark.

If unsure about your MIDI-CV converter's specifications, consult the manufacturer's literature.

Chart 1

Translating MIDI Continuous Controller Values To Vowel Positions

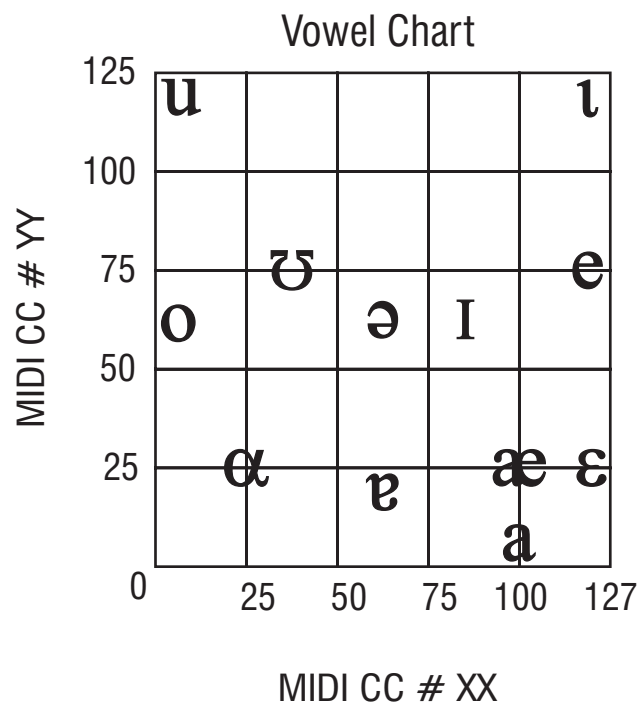

Pronunciation Guide *

u	BOOT
l	FREE
ʊ	HOOK
e	PLAY
i	BIT
o	GO
ə	TINA
ε	BED
a	STACK
α	HOT
æ	CAT
ɚ	NUT

This chart is valid for MIDI-CV converters with 5 volt output range.
 This is typical of the Aux Output on many converters.
 Set the Formant Filter's knobs as recommended in Patch 1.

* N. American English

Patch 2

Two Axis Vowel Synthesis with Analog Joystick

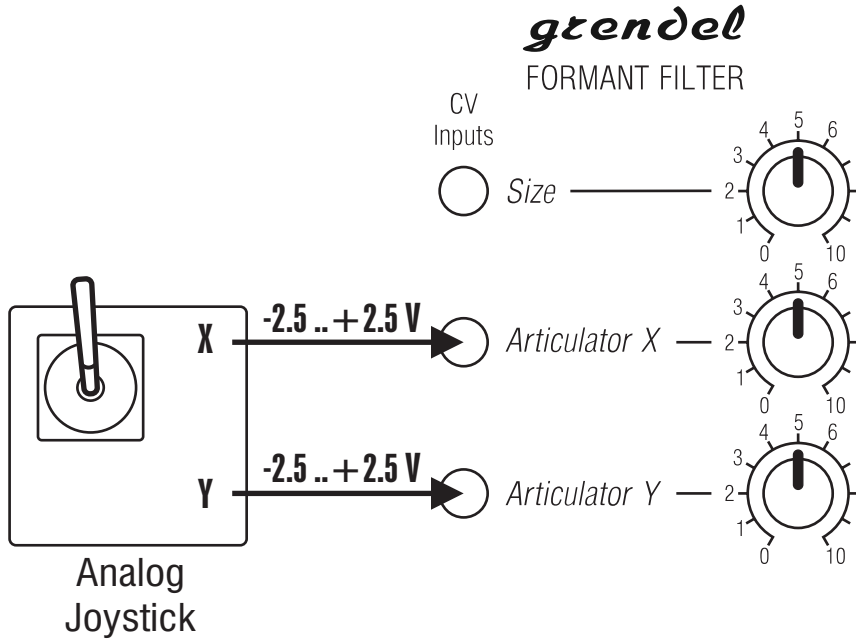

If the joystick has bipolar output, such as -2.5 .. +2.5 volts, set both Articulator knobs to the 5 mark.

If the joystick's output range is 0.. +5 volts, set the Articulator X and Articulator Y knobs to the zero mark. This provides correct offset bias for full range of control.

It is OK to use a joystick with wider output range than 5 volts, but it will mean a narrower useful region of joystick travel. Patch a voltage attenuator in between the joystick and filter to correct this.

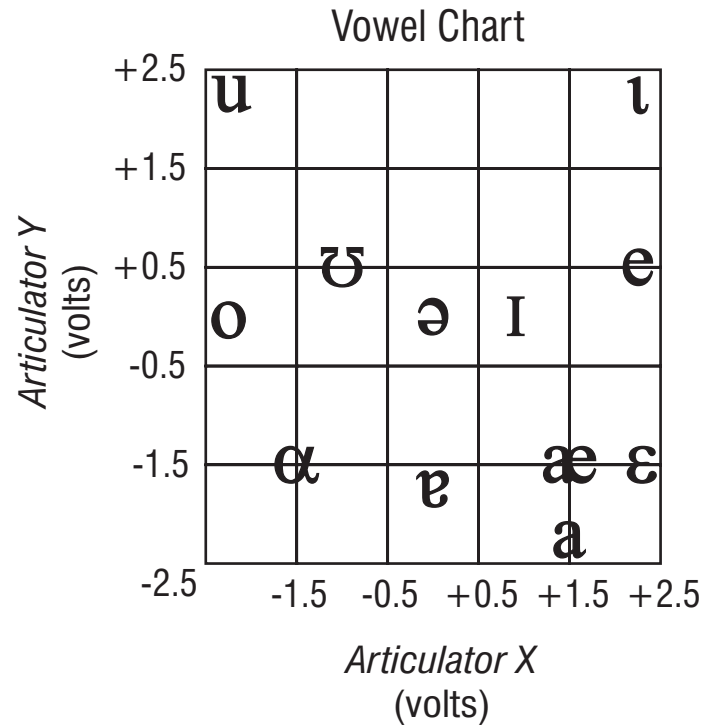

Pronunciation Guide *

u	BOOT
ʊ	FREE
ʊ̃	HOOK
e	PLAY
ɪ	BIT
o	GO
ə	TINA
ɛ	BED
a	STACK
ɑ	HOT
æ	CAT
ɚ	NUT

* N. American English

Patch 3

Classic CV-Gate Monosynth With Formant Effect

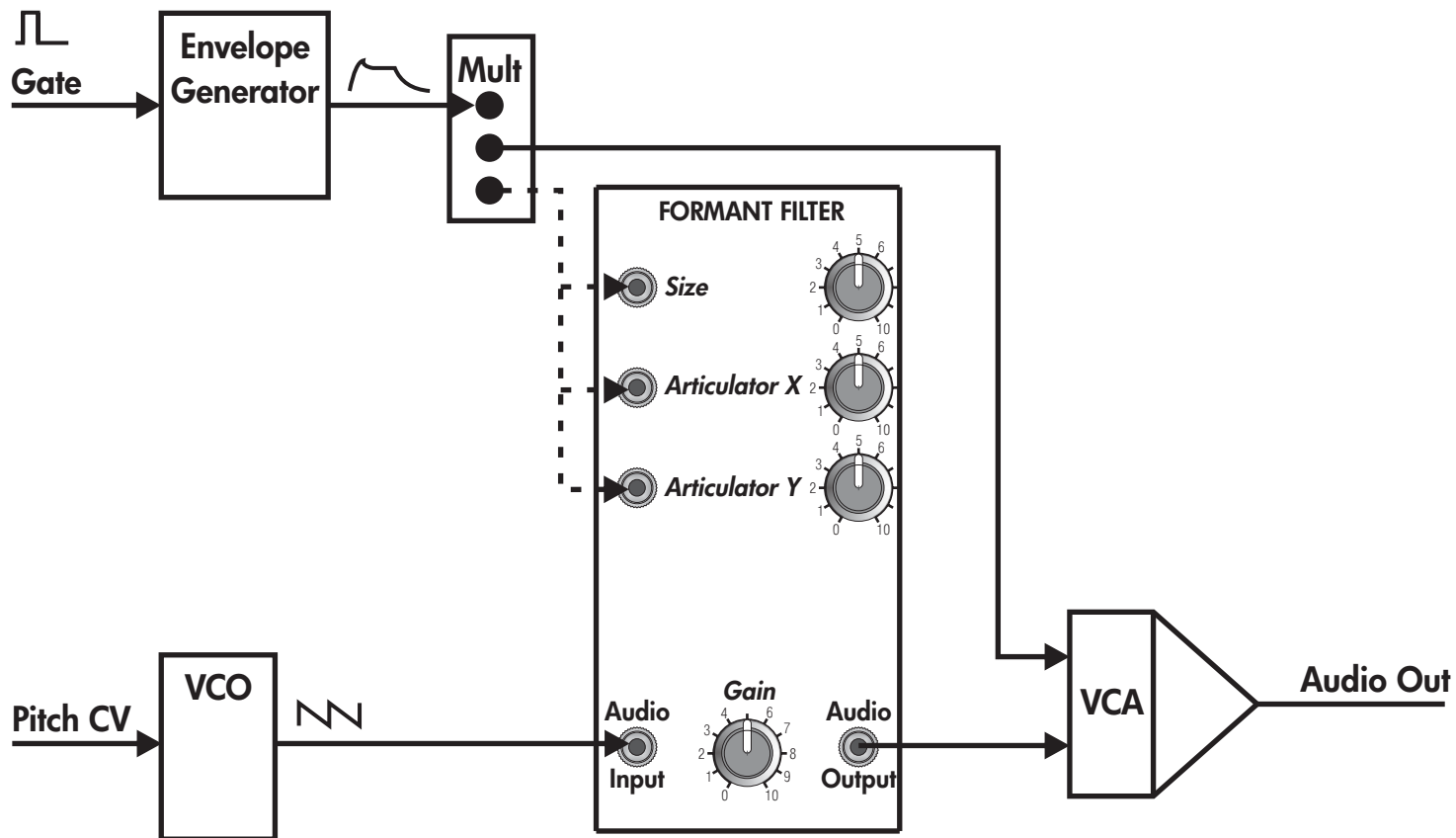

Patch 4

Adding LFO Filter Effects To A Keyboard

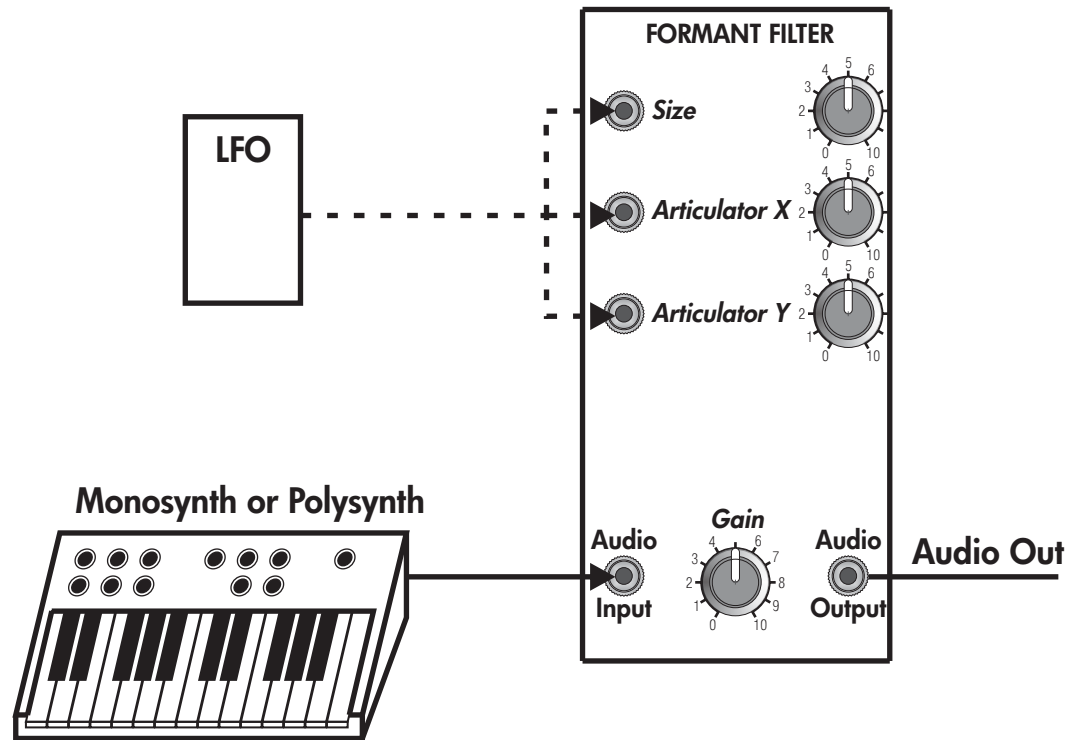

Patch 5

Stepped Random Formant Effect

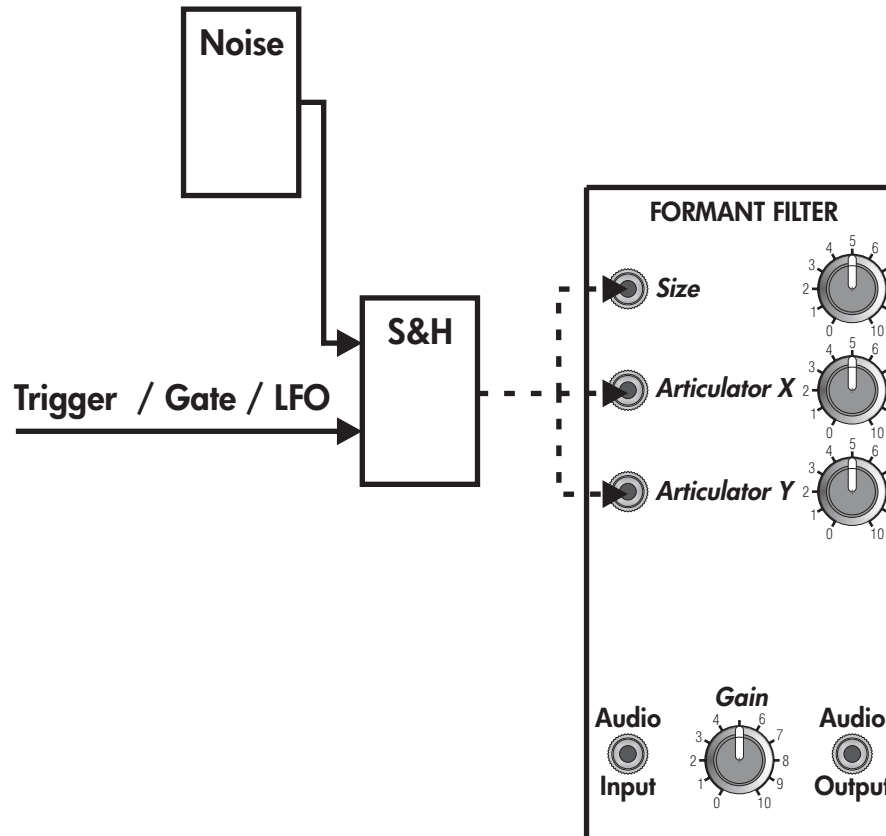

Patch 6

Breathy Voice Simulation

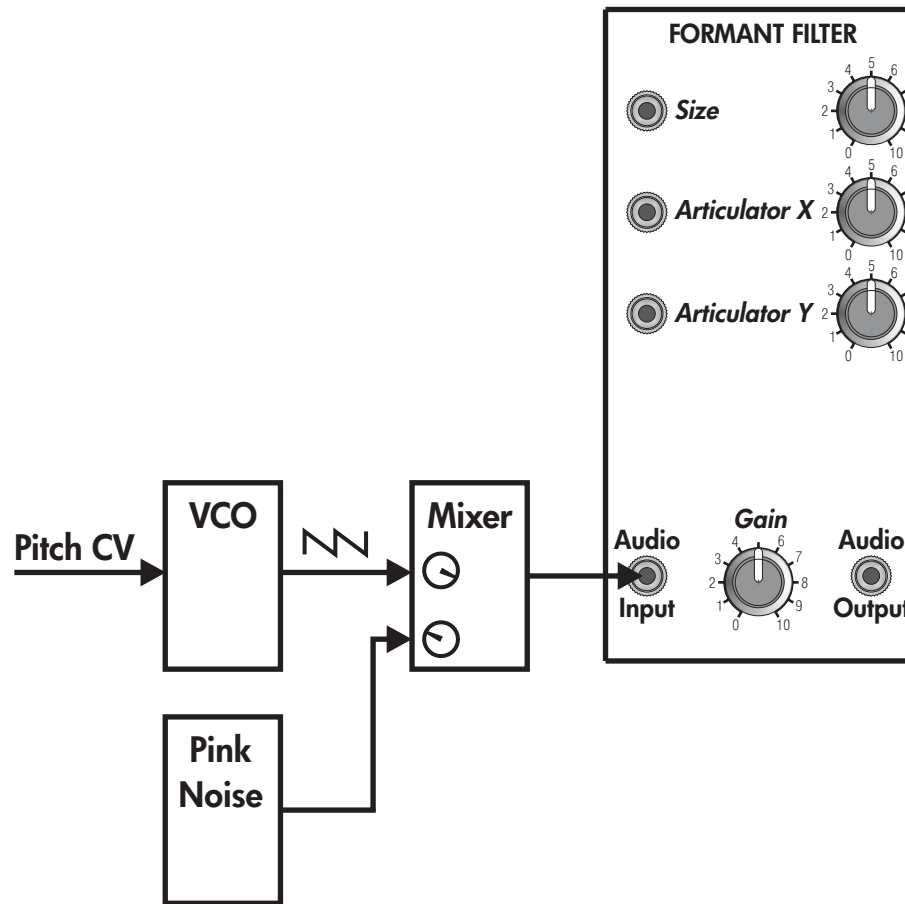

Patch 7

Stepped Pattern Formant Effect

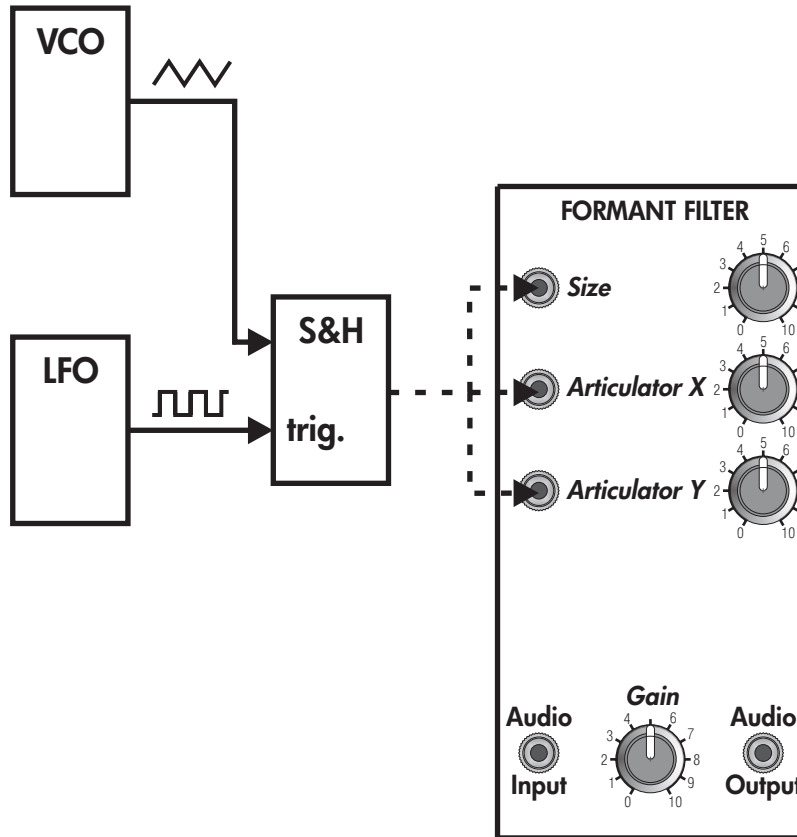

Patch 8

Vocal Waveform Simulation I

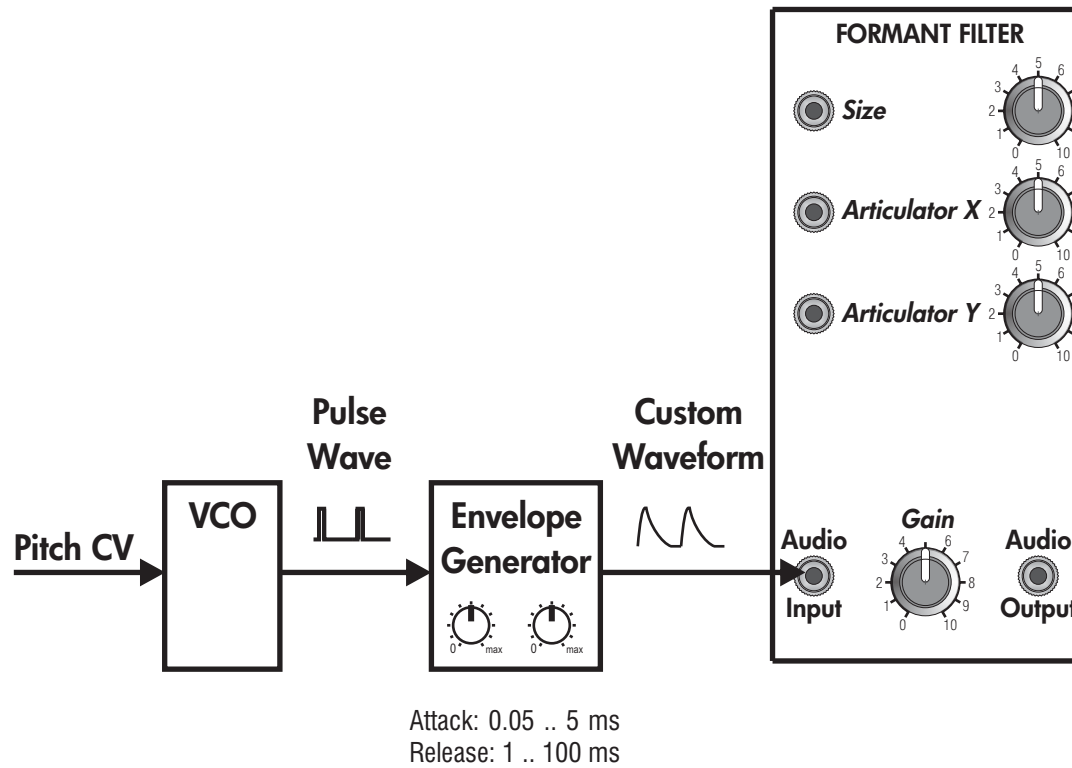

Patch 9

Vocal Waveform Simulation II

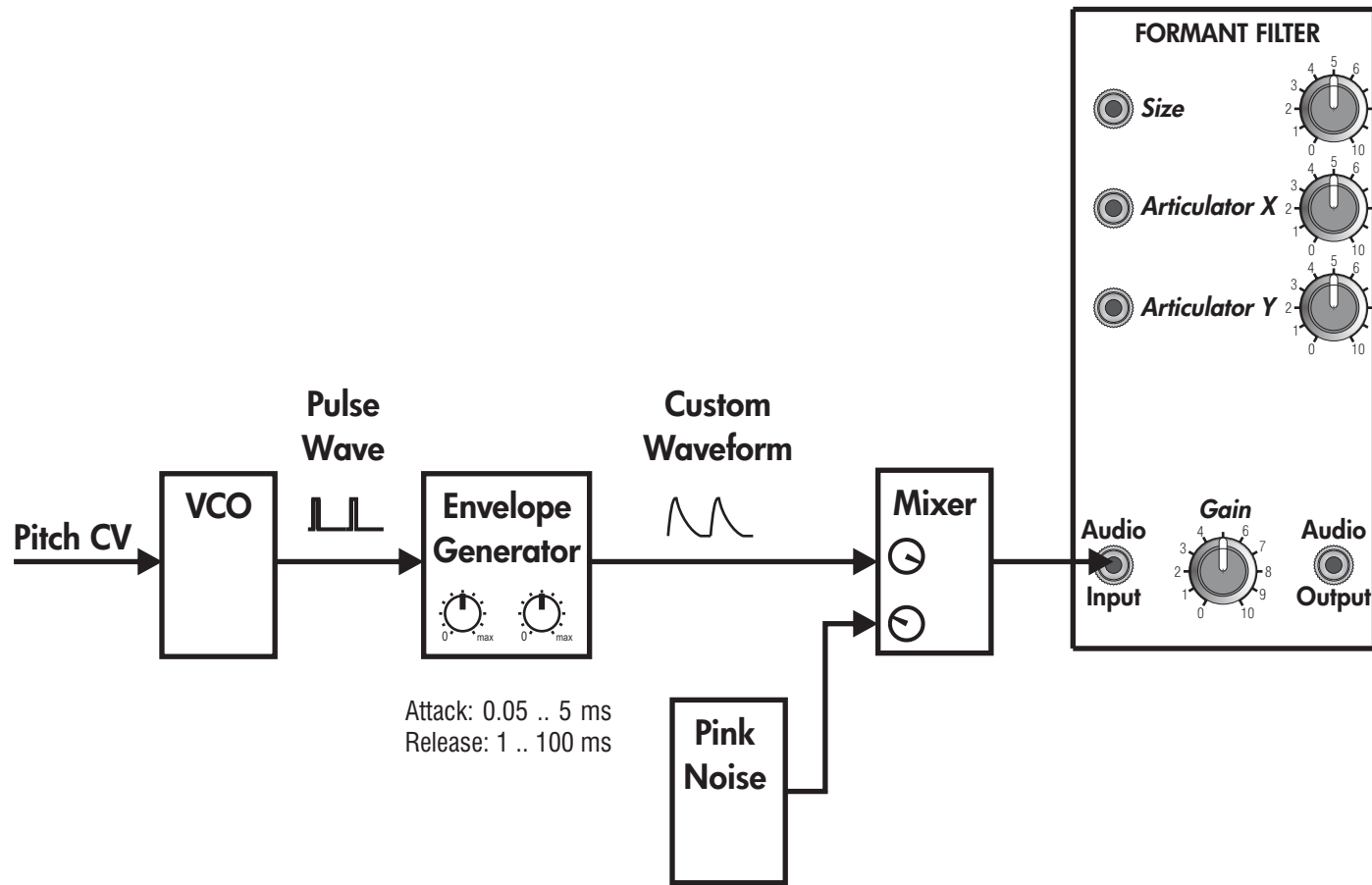

Patch 10

Keyboard Performance with Formant Expression Control

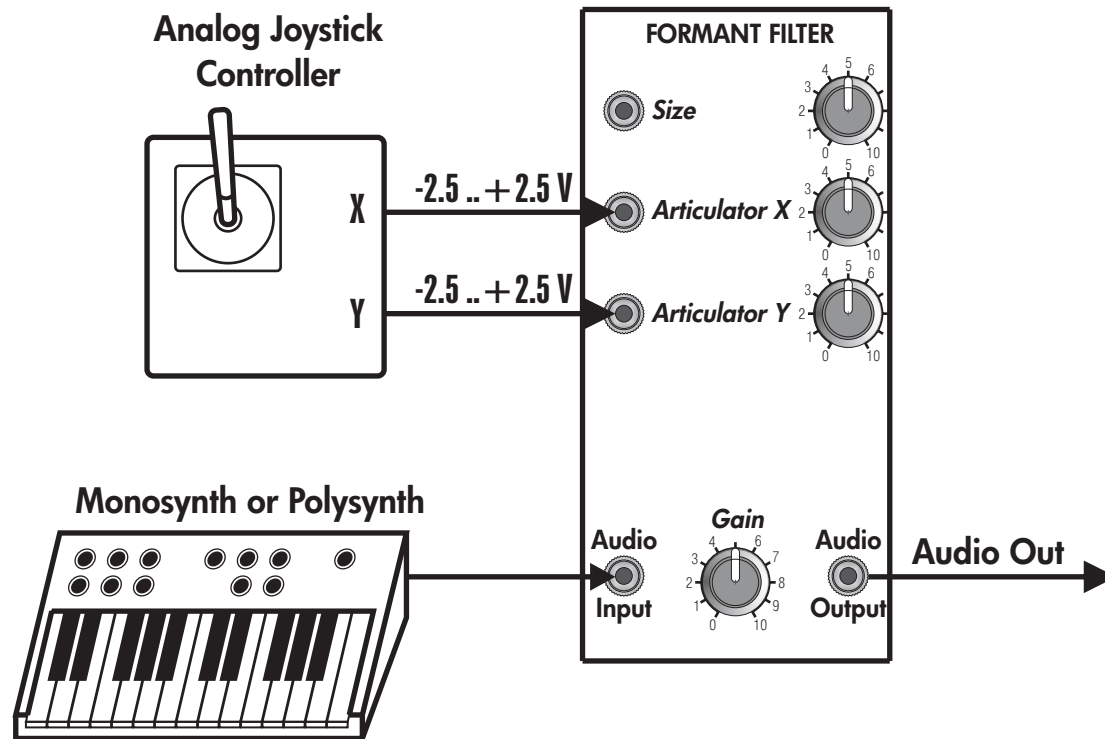

Patch 11

Sequenced Monosynth With Vocal Effect

