

GURUS[®]

CICOGNANI BOUTIQUE SERIES



Gurus Amps si riserva il diritto di modificare le caratteristiche tecniche ed estetiche dei prodotti in qualsiasi momento e senza preavviso. Questo prodotto osserva i requisiti delle Direttive Europee 89/336EEC

Gurus Amps reserves the right to change technical features or look of his products in any moment without notice. This product is pursuant to European Directives 89/336EEC

19 DOUBLE 59 DECKER

USER'S MANUAL (ENG)

The 1959 Double Decker Introduction:

Inspired by the legendary British tone of 1959, The Double Decker combines the two worlds of historic amps, from blues to hard rock in one device. From slight crunch and sexy tone to boosted hi-gain levels. We also doubled its potential uses, from the big stage to the bedroom. The 1959 Double Decker can be used with an amp or DAW and everything is doubled!

1959 Double-Decker features:

- Two independent channels equipped with Gain, Volume and an entire tone stack for better sculpting of your tone.
- Post Boost with Volume control can be activated on all three stages of the unit, (Bypass, Floor 1, Floor 2) and it is self-disengaged simply by pressing another button.
- Tube FX Loop with series/parallel switch (especially useful when used with amps with no effects loop or series only)
- Remote outs for connections with analog switchers.
- Balanced/unbalanced D.I. Out with Direct/Emulated option (Speaker Sim. of a 2x12" - V30/SM57) that can be used simultaneously with the standard output of the unit or alone as interface for excellent quality audio recordings.

When we designed the 1959 DD, we always kept in mind the sound we wanted to produce with rich details, harmonics and an organic sound with tons of dynamics: an "in-your-face" tone. We also wanted to create a device which could easily obtain these great tones with effective and intuitive controls. 1959 DD required a lot of engineering work to fit the size, despite using the high quality components normally used in amplifiers and with the important consideration of space. To keep the standard pedals power supply (9-12VDC Negative tip), we pushed our Twin Dynamic™ over the limit, making it able to increase the input voltage many times so as to obtain the maximum dynamic range of the signal. 1959DD is your perfect companion on the stage, both as an "Overdrive warehouse" on your large pedal board, or in a small setup with the effects placed in the loop. It is also great for studio or home use providing your records an excellent starting point for your guitar sound, Simply connecting it to your PC with or without Speaker simulator.

Terms of Warranty

Gurus product warranty covers 2 years from date of purchase with the exception of moving mechanical parts such as foot switches, speakers and handles which have a 1 year warranty. The valves, lights and cables are guaranteed for 3 months from the date of purchase.

The warranty does not cover damage caused by accident, misuse and / or neglect, failure to comply with the instruction manual, repair and attempted repair by personnel not authorized by Gurus Amps, any damage caused during transport and delivery, (claims must be presented to the carrier); damage to any product that has been altered or on which it has been removed, defaced or altered serial number; damage caused by faulty connections or connections to equipment failures and/or defective power cables.

Responsibility of Gurus Amps for any defective product is limited to repair or replacement of the product at our discretion.

The Gurus Amps is not to be considered liable for damages resulting from loss of use of the product, lost time operation interrupted by non-use of the product, loss of business or any other damages or incidental, consequential or otherwise; damage in transit or damage caused by inadequate packaging or of poor quality.

Assistance: Please contact us for information on how, where and when to ship the product. The repaired goods will be packed carefully and we recommend not include any accessories such as cables, effects, manuals, etc. ..Please attach a copy of the original receipt of purchase (invoice or receipt) together with a problem description and your personal data.

THE WARRANTY IS NOT VALID 'WITHOUT A COPY OF YOUR RECEIPT OF SALE CERTIFYING THE DATE OF PURCHASE.

The costs of labor and material guarantee shall be borne by Gurus Amps. PACKING AND SHIPPING COSTS ARE ALWAYS IN CHARGE TO CLIENTS.

Rear panel's connections:

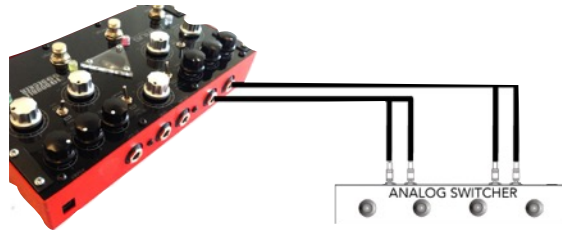

Use the FTSW1/2 Out to remote all 4 function buttons by a looper switcher with a Trs Jack Stereo/Dual Mono "Y" - "insert" cable.

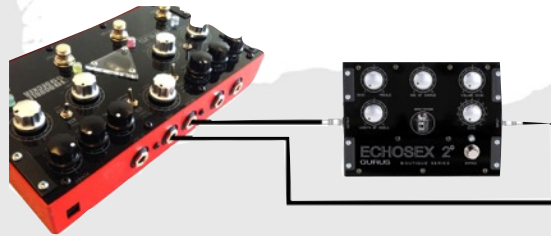

With the Send/Return Out you can connect your favorite FX chain into the 1959DD'S buffered Fx Loop, being able to select Serial or Parallel Mode for best results.



Use the D.I. Out to connect to your DAW or to Mixing Console, being able to choose direct or emulated out you are free to use Plug ins Cab. sim.or have a great tone with our own Spk. Sim. (It can be used simultaneously with unit's out)

General Details:

Power 9VDC (Negative Tip)	230 mA
Power 12VDC (Negative Tip)	280 mA
Max Consumption	300mA
S/N Ratio	58db
Max Gain	98db
Max Boost	8db
Input Impedance	<1M Ohm
Output Impedance	<100K Ohm
Send Impedance	<100K Ohm
Return Impedance	<100K Ohm
D.I.Out Impedance	<47K Ohm
Serial FX Loop	0db
Parallel FX Loop (50%)	0db
Max Return Signal	0,3Vpp
Max D.I.Out Signal	0,1Vpp
Dimensions	220x125x50mm.

Connections:

Main Power:	DC 2,1mm.
Input	Guitar Input
Output	To Amp In
Send	To FX In
Return	To FX Out
D.I.Out	To DAW, Mixer, etc

Controls Floor 1:

Gain Floor 1	65db
Volume Floor 1	0 to +10db
S/N Ratio	52db

Tone Stack:

Treble	7800Hz +/-12db
Middle	850Hz +/-10db
Basse	120Hz +/-10db

Controls Floor 2:

Gain Floor 2	98db
Volume Floor 2	0 to +10db
S/N Ratio	58db

Tone Stack:

Treble	6500Hz +/-12db
Middle	1000Hz +/-10db
Basse	120Hz +/-10db

Others:

FSW 1:	Bypass/Floor 1
FSW 2:	Floor 2/Solo
Series	100% Post EQ Mix
Parallel	50% Post EQ Mix
Direct	No SPK. Sim. +4db
Emulated	SM57 + 2xV30

1959 DD Block Diagram:

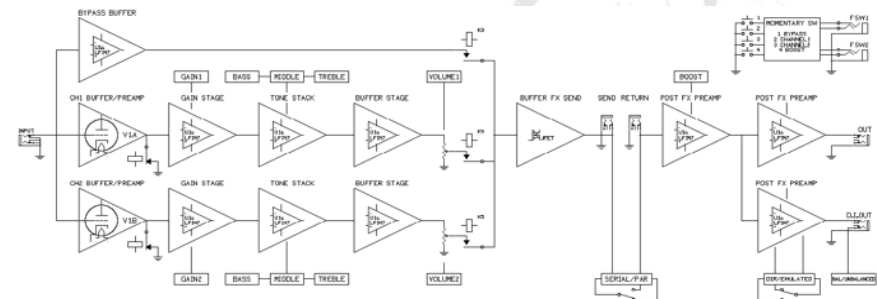

Floor 1 - SEXY - 59's Edge

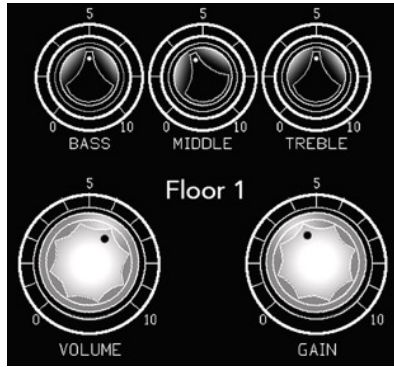

Floor 2 - LEAD1 - Rhythmic

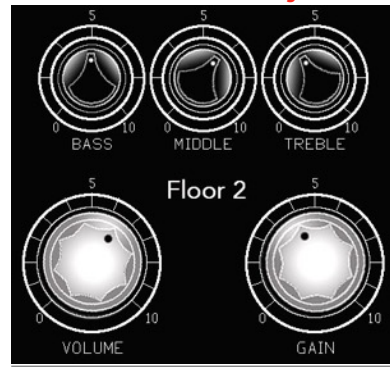

Floor 1 - CRUNCH - 70's



Floor 2 - HEAVY LEAD -



Floor 1 - HEAVY - Crunch

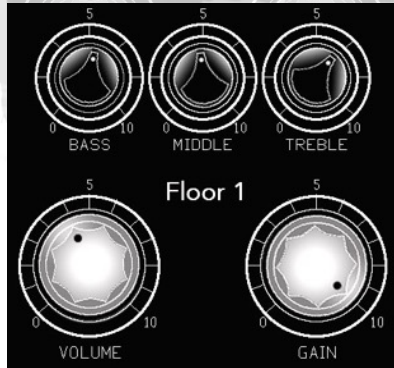

Floor 2 - LEAD2 - 80's Rock



1959 Double Decker Features so many functions as 8 single pedals to obtain same flexibility. And they wouldn't probably be enough! The Double decker is equipped with HQ buffers and its Solo maybe used also on the Bypass mode, just like a third pedal.

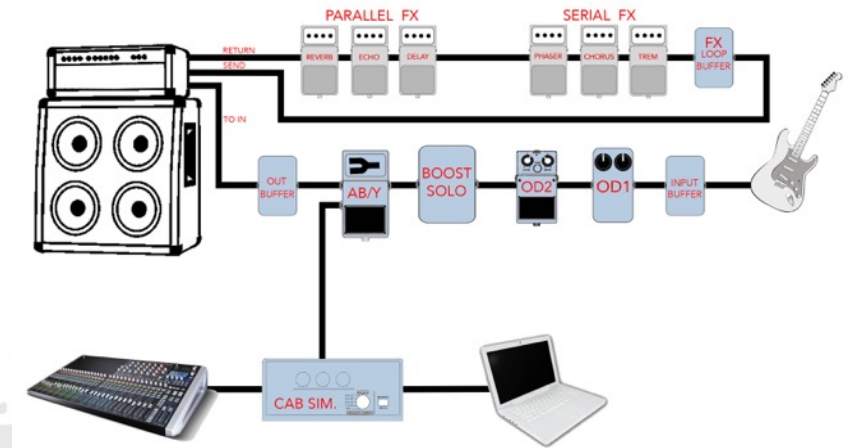

As in the sample rig below, you can use your 1959DD both in front of amp and, via the D.I.out, to mixer or DAW simultaneously for a nice live monitoring or excellent quality live recordings.

